



SAFETY RECALL

Release Date: April 12, 2022

RZR

Communication #: Z-22-01

Model Year(s): 2022

— Confidential and Proprietary —

VERSION: R02 (April 12, 2022)

**** Converted from Stop Sale / Stop Ride to Safety Recall ****

IMPORTANT STOP RIDE / STOP SALE SAFETY NOTICE!

Stop selling affected vehicles immediately until the repair procedure has been completed on affected units at your dealership. Federal law prohibits the sale of products subject to a recall. Selling such products could subject the seller to substantial penalties.

IMPORTANT

If you are working with a printed copy, please verify you have the most current version of this document.

SUBJECT: BATTERY CABLE ROUTING

PURPOSE

Polaris has determined that some Model Year 2022 RZR Pro R 4 Premium and Ultimate vehicles may have an incorrectly routed auxiliary battery positive cable, which may contact the prop shaft during vehicle operation. Prolonged contact of the battery cable with the prop shaft may result in an electrical short, posing a fire hazard and risk of serious injury.

This Safety Recall provides instructions to inspect and re-route the affected battery cable. In limited cases where the cable insulation has been damaged, replacement of the auxiliary battery connection cable may be required.

AFFECTED MODELS

MODEL YEAR	MODELS	AFFECTED RANGE
2022	RZR Pro R 4 Premium / Ultimate	Reference Unit Inquiry on the dealer website or the Service Communications list on the STOP site to look up affected units.

CUSTOMER NOTIFICATION

Dealers are required to review their sales records and make arrangements with customers for Safety Recall completion. In addition to consumer units, dealers are required to correct any affected units in their inventory. Polaris will be mailing a notification letter to consumers affected by this Safety Recall.

CONTACT POLARIS

If you have questions that are not addressed in this document, contact Polaris Service through Ask Polaris or by phone at 800-330-9407 (US/Canada Dealers Only).

DEALER - WHAT TO DO?

As of April 4, 2022, **YOU MUST NOT SELL OR DELIVER** any affected **NEW OR USED Model Year 2022 RZR Pro R 4 Premium / Ultimate** affected by this **Stop Sale / Stop Ride** until it is repaired according to the **Safety Recall** bulletin.

WARRANTY CLAIM INFORMATION

INSPECTION PASS BATTERY CABLE RE-ROUTE RZR PRO R 4 PREMIUM / ULTIMATE	
Bulletin #	Z-22-01-A
Claim Type	SB (Service Bulletin)
Labor Allowance	1.3 hours (78 minutes)
Part Number / Description	7081916 (QTY 2) STRAP-PANDUIT,DBL LOOP,260MM
Parts Availability	Available to order
University of Polaris Video Training Required	NO

Claim Submission:

- **US / Canada Dealers:** On DEX, go to Service and Warranty > Warranty Claim and Extended Coverage > Start a New Warranty Claim. Select Service Bulletin > Enter the VIN / PIN and Retrieve Registration. Select Z-22-01-A and Send Claim.
- **International Dealers:** On iDEX, go to Service and Warranty> Warranty Claims>Start a New Warranty Claim. Select Service Bulletin > Enter the VIN / PIN and Retrieve Registration. Select Z-22-01-A and Send Claim

INSPECTION FAIL BATTERY CABLE REPLACEMENT RZR PRO R 4 PREMIUM / ULTIMATE	
Bulletin #	Z-22-01-B
Claim Type	SB (Service Bulletin)
Labor Allowance	1.8 hours (108 minutes)
Part Number / Description	2416131 (QTY 1) CABLE-POS,DUAL BATT,RZR PROR <div style="background-color: #006633; color: white; text-align: center; padding: 2px;">IMPORTANT</div> Parts should ONLY be ordered if the auxiliary battery positive cable is found to fail the inspection.
Parts Availability	Limited quantities available through 04/18/2022
University of Polaris Video Training Required	NO

Claim Submission:

- **US / Canada Dealers:** On DEX, go to Service and Warranty > Warranty Claim and Extended Coverage > Start a New Warranty Claim. Select Service Bulletin > Enter the VIN / PIN and Retrieve Registration. Select Z-22-01-B and Send Claim.
- **International Dealers:** On iDEX, go to Service and Warranty> Warranty Claims>Start a New Warranty Claim. Select Service Bulletin > Enter the VIN / PIN and Retrieve Registration. Select Z-22-01-B and Send Claim

The information contained within this document is confidential and protected by U.S. and international copyright laws, and is the property of Polaris Inc. This document is provided for the sole use of authorized Polaris dealers and distributors. This document is not to be distributed, duplicated, or copied, digitally or otherwise, without the written consent of Polaris Inc.

DECLINED SAFETY RECALL

Polaris provides a claim process that allows dealers to accurately document when a Safety Recall cannot be performed on a vehicle due to modification. Criteria and instructions can be found under Service & Warranty > STOP Site > News, Forms, & Links > Declined Safety Bulletin Tracking.

US & CANADA TRANSPORT & MOBILE SERVICE REIMBURSEMENT

Polaris will authorize travel or transport up to 1.0 hour of labor to perform the bulletin. Wholegood stock vehicles are not eligible for travel / transport coverage reimbursement. Polaris recommends that dealers work with vehicle owners to determine the best solution for their situation. To obtain travel / transport reimbursement, enter the actual labor time up to 1.0 hour, into the Travel Hours or Travel Minutes on the bulletin claim.

ACCESSORY LABOR

Polaris will cover labor for the removal and installation of accessories required to complete the bulletin work. Follow the steps below to obtain reimbursement.

For accessory removal and installation up to 30 minutes of labor:

Enter the actual labor time for the removal and installation into the Accessory R&R Min Field on the bulletin claim.

For accessory removal and installation over 30 minutes of labor:

1. Start a new Ask Polaris Case, Service & Warranty Question > Authorization: In Warranty or Polaris ESC or Authorization: Out of Warranty.
2. Enter your contact information and VIN / PIN, along with miles and hours into the applicable fields.
3. Enter Z-22-01 in the CONCERN and CAUSE fields. In the CORRECTION field, enter "ACCESSORY REMOVAL AND INSTALLATION".
4. Enter warranty fail codes 127/277/153.
5. Add part 0000541, quantity 1.
6. Attach photos of the vehicle and accessories sufficient to support the labor time requested.
7. Submit the case to Polaris.

COVERAGE PERIOD

Coverage will begin on April 12, 2022. This bulletin has no expiration date.

PARTS RETURN / DISPOSAL INFORMATION

Under no circumstances shall the parts removed be re-used, sold, or re-purposed for another application. It is your dealership / distributor's responsibility to make sure every part replaced (related to this communication) is taken out of circulation and disposed of properly or returned to Polaris (if required).

FEEDBACK FORM

A feedback form has been created for the technician to provide Polaris with an overall satisfaction rating for the instructions, provide comments on your experience or upload pictures/video. The form is viewable on mobile devices by scanning the QR code or on a PC by clicking [HERE](#).



REPAIR OVERVIEW

In this procedure, inspect the auxiliary battery positive cable ②, which runs between the auxiliary battery and the primary battery, for damage according to the inspection procedure. Damaged cables will be replaced. The cable will then be re-routed so that it passes **OVER** the seat base bracket ③, rather than **UNDER**. Routing the auxiliary battery cable under the seat bracket can cause the cable to contact the front prop shaft and cause damage to the cable.

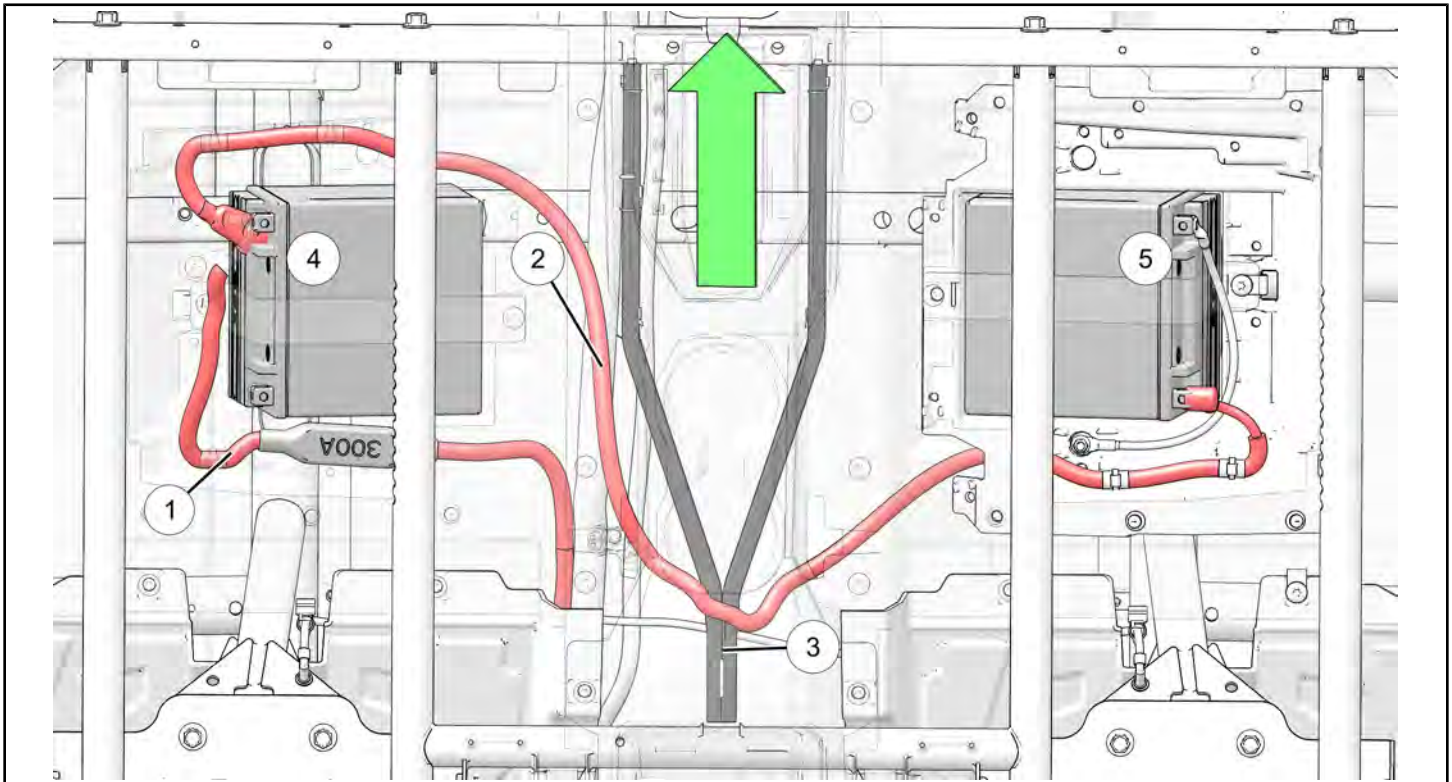

NOTICE
The green arrow is pointing towards the front of the vehicle.

- ① Primary Battery Cable (Drivers Side Battery to PDM)
- ② Auxiliary Battery Cable (Drivers Side Battery to Passenger Side Battery)
- ③ Seat Base Bracket (Wishbone Bracket)
- ④ Primary Battery (Drivers Side Battery)
- ⑤ Auxiliary Battery (Passenger Side Battery)

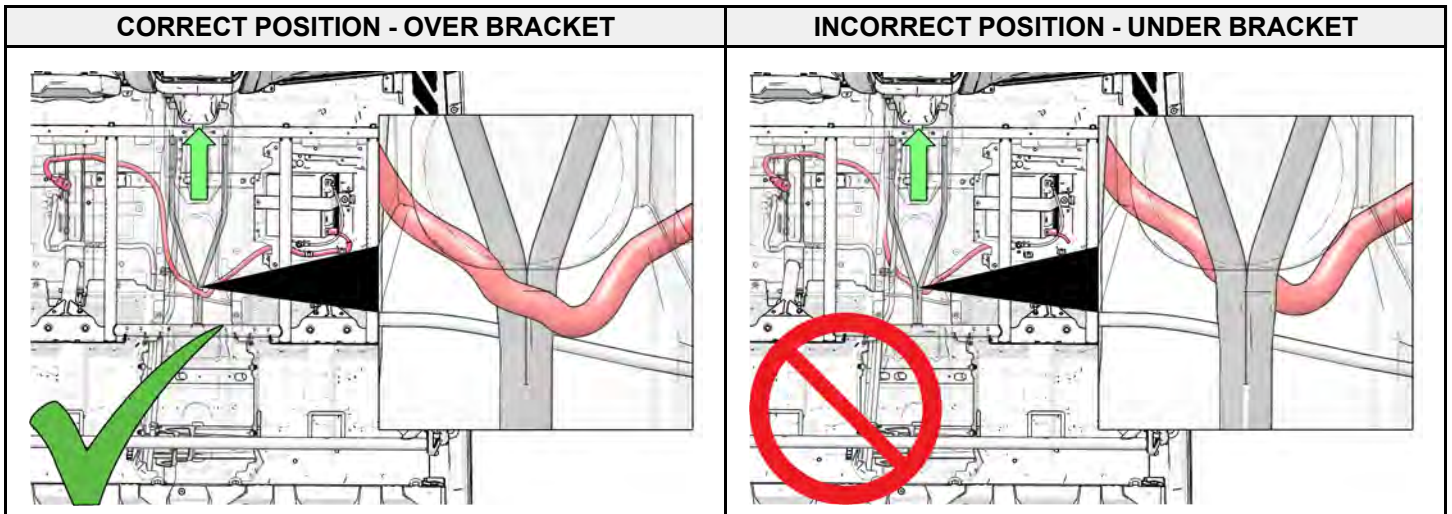

The information contained within this document is confidential and protected by U.S. and international copyright laws, and is the property of Polaris Inc. This document is provided for the sole use of authorized Polaris dealers and distributors. This document is not to be distributed, duplicated, or copied, digitally or otherwise, without the written consent of Polaris Inc.

AUXILIARY BATTERY CABLE ROUTING RETAINING POINTS

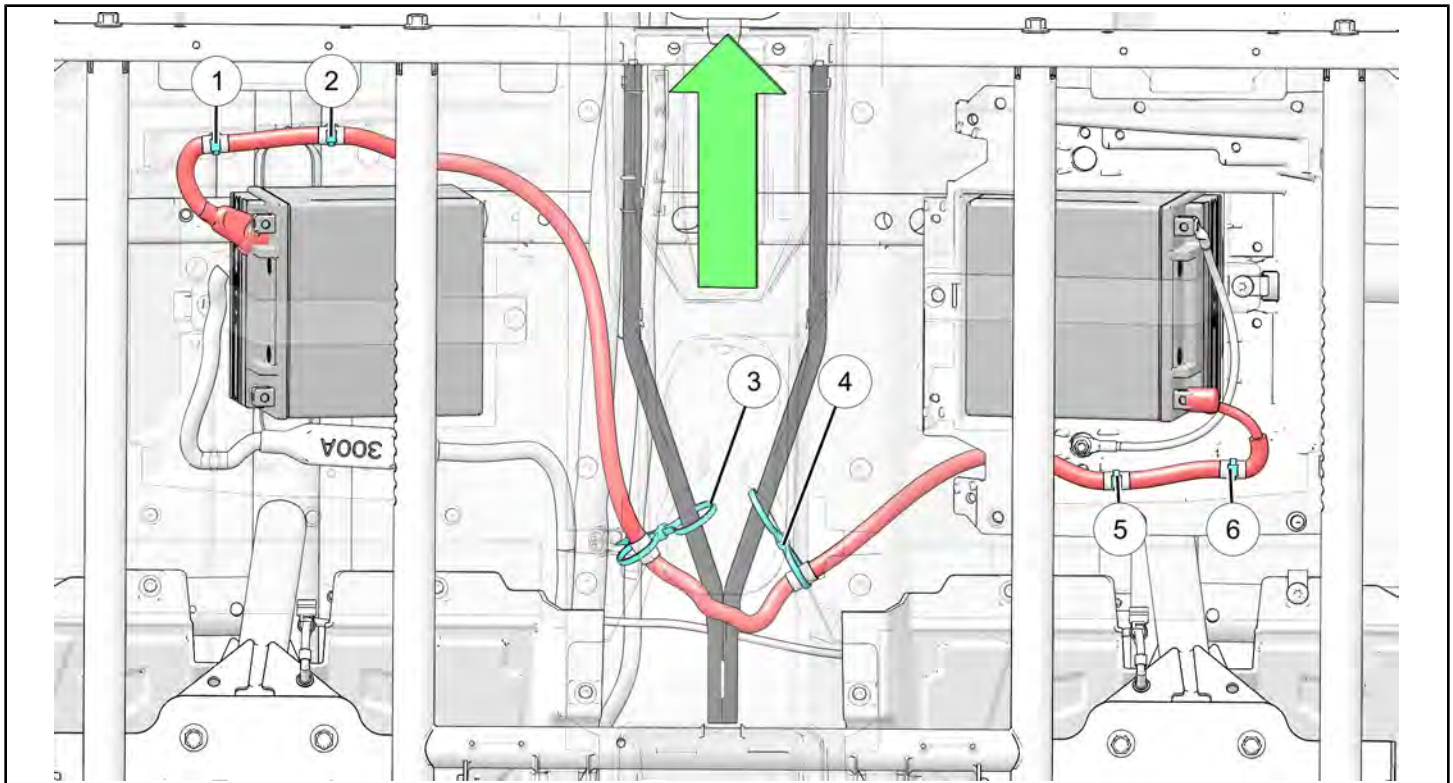

① Cable Tie / Push Clip

② Cable Tie / Push Clip

③ Double Loop Cable Tie Strap (P/N 7081916)

④ Double Loop Cable Tie Strap (P/N 7081916)

⑤ Cable Tie / Push Clip

⑥ Cable Tie / Push Clip

AUXILIARY BATTERY POSITIVE CABLE INSPECTION

TOOLS REQUIRED

- Safety Glasses
- Pliers, Push Pin Rivet
- Pliers, Side Cutting
- Socket Set, Metric
- Socket Set, Torx® Bit
 - T40
- Torque Wrench
- Abrasion-resistant electrical tape (Coroplast 837X, 3M Scotch 22, or similar)

INITIAL STEPS

1. Park vehicle on a flat surface.
2. Shift vehicle into PARK.
3. Turn key to OFF position and remove key.

SEAT REMOVAL / BATTERY DISCONNECT

1. On the drivers front seat, pull up on the lever, located below the front of the seat.

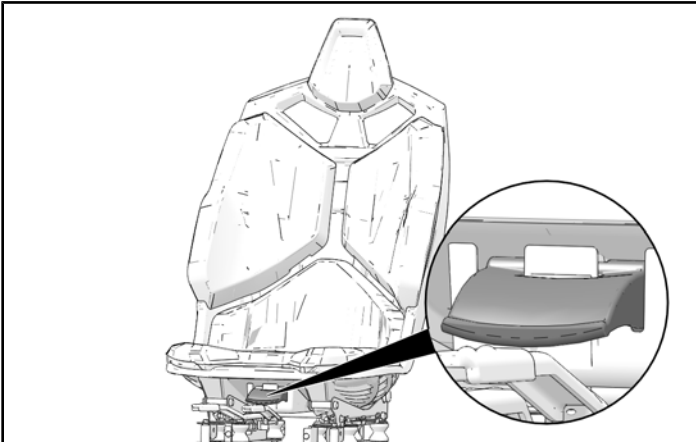

2. Tilt the seat assembly forward. Hold the seats in this position by attaching the seat to the ROPS using a bungee cord or strap.

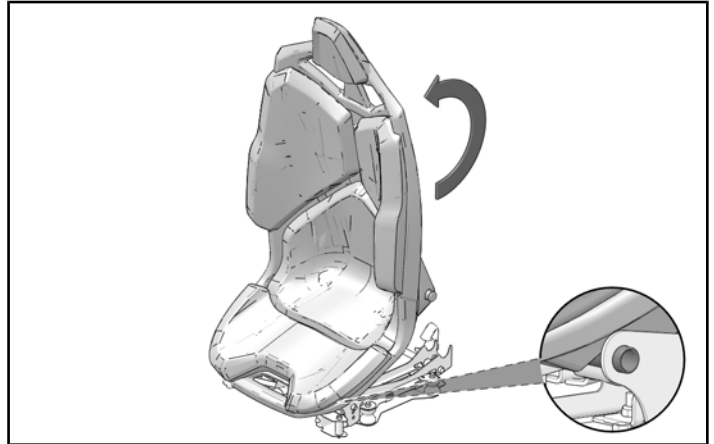

3. Repeat these steps for the passenger front seat.
4. Remove the battery terminal fastener and washer, disconnect the cables in the following order:
 - a. On the primary battery negative battery cable.
 - b. On the auxiliary battery negative battery cable.
 - c. On the auxiliary battery positive battery cable.

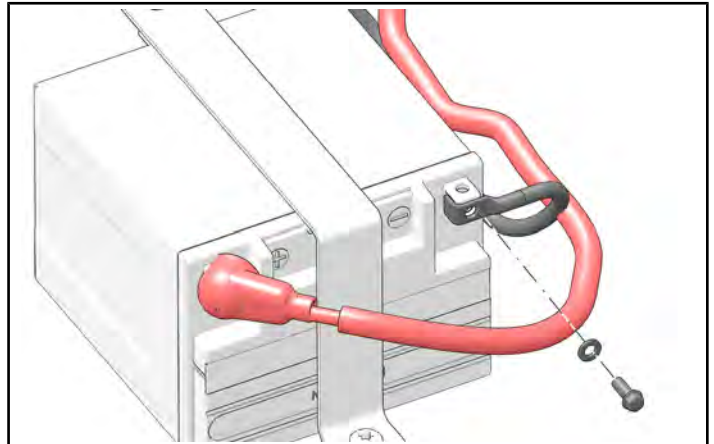

IMPORTANT

Use caution when removing the battery cables. The cables that connect the battery are not fused and could cause damage if these cables are shorted to power or ground.

Cover the exposed battery terminals and cable ends with electrical tape to prevent incidental electrical contact.

- Remove the auxiliary battery positive cable protective boot from the positive battery cable on the auxiliary battery. This will be installed following cable re-routing.

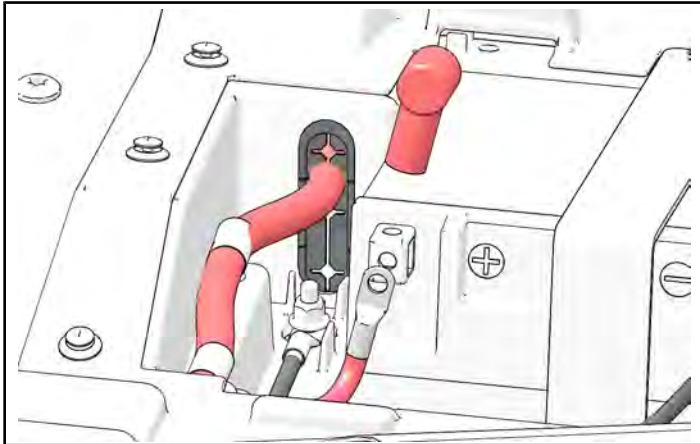

- In the auxiliary battery compartment, cut the positive battery cable routing cable ties ①.

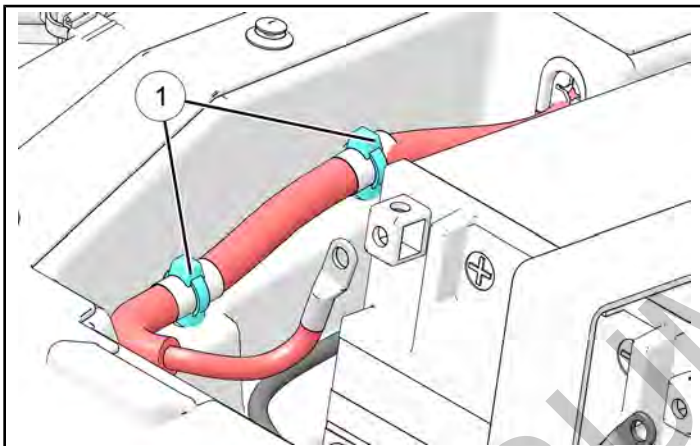

IMPORTANT

Make sure not to damage the auxiliary battery cable when cutting the cable ties.

STOP!

All battery cables except the primary battery (drivers side) positive cable (red) should be disconnected before continuing service.

REAR CENTER CONSOLE REMOVAL

- Unlatch the rear seats and remove the rear seat backs.
- Remove the cotter pin and unbuckle the rear seat, inner thigh belt clasps. The cotter pin will be installed during rear console installation.

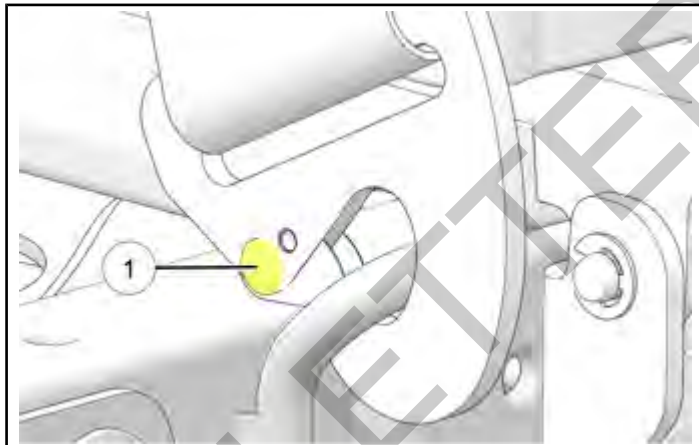

- Raise both rear seat bottoms to access the fasteners for the rear under-seat panel.
- Remove the fasteners ① from the front of the rear under-seat panel.

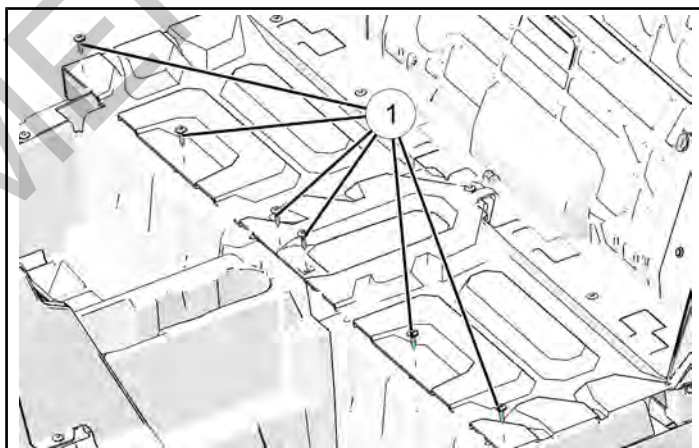

5. Remove the torx fasteners ② from the left side of the rear center console.

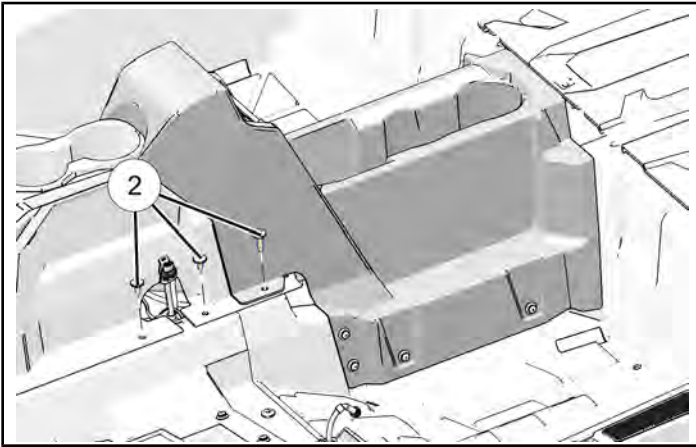

IMPORTANT

The rear torx fastener is longer than the other two. Make sure that the longer fastener is installed in the correct position during rear center console installation.

6. Remove the push rivets ③ from the left side of the rear center console.

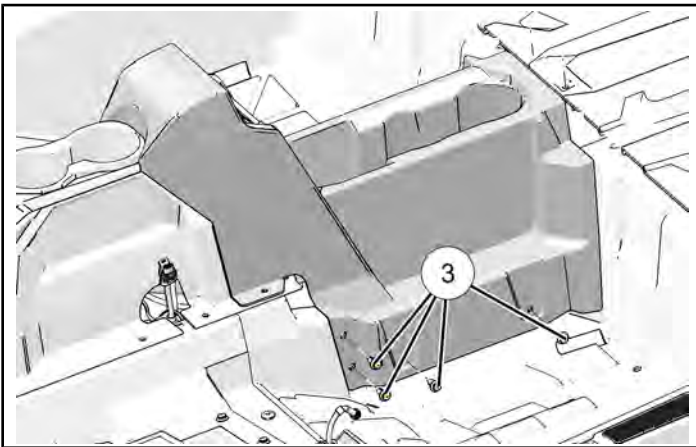

7. Repeat fastener and push rivet removal on the right side of the rear center console.

8. Remove the rear console net pocket storage compartment.

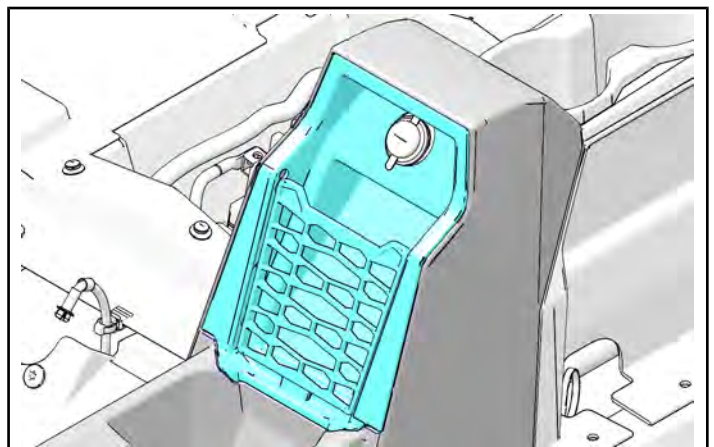

9. Remove the rear center console from the vehicle.

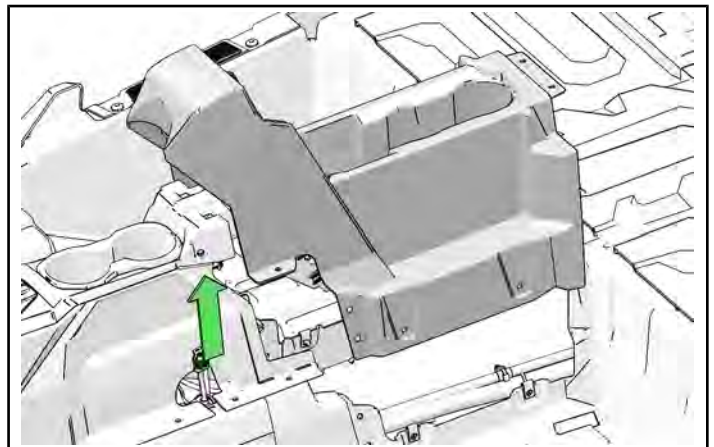

NOTICE

The rear under-seat panel will need to be lifted and pulled back to allow the rear center console to be removed from underneath the panel.

10. Move the front center console side panels outward and attach the rear portion of the front center console to the seat frame using cable ties to allow for better access.

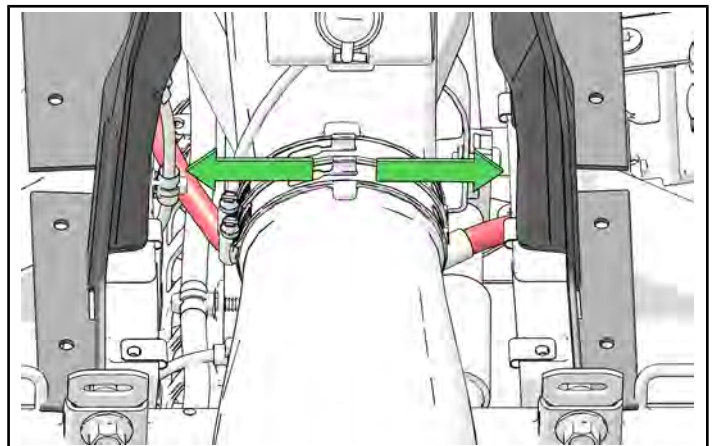

AUXILIARY BATTERY POSITIVE CABLE INSPECTION

1. Pass the auxiliary battery positive cable through the grommet ① in the passenger side battery compartment.

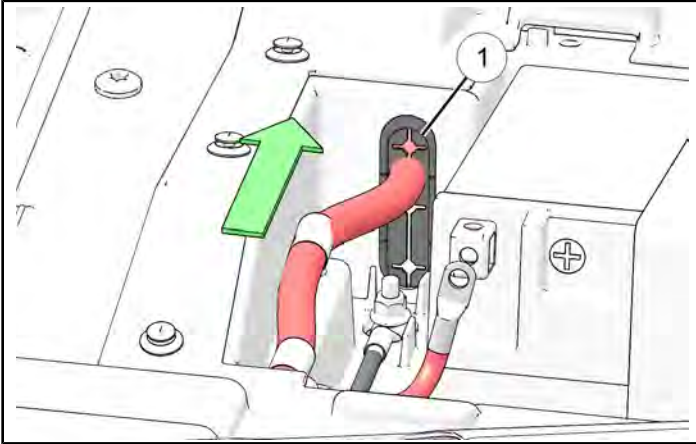

2. From the passenger rear, locate the auxiliary battery positive cable under the clutch duct and seat brackets.

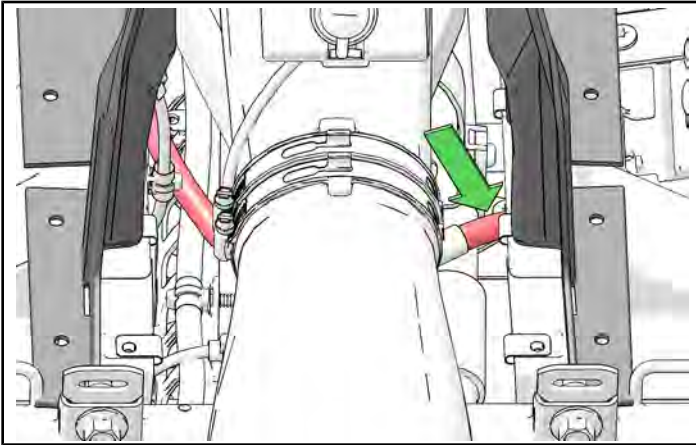

3. If the auxiliary battery positive cable is attached in any location under the center console or clutch duct, cut the cable ties. These will be replaced when the cable is re-routed.

IMPORTANT



Make sure not to damage any electrical harnesses in the area of additional cable ties, or the auxiliary battery positive cable, when cutting the cable ties.

4. Working from the drivers rear seat area, pull the free end of the auxiliary battery positive cable until the area between the two tape marks ① and ② is visible.



5. Inspect the auxiliary battery positive cable between cable routing clip ① and ②. Check for any rub through or damage to the auxiliary battery positive cable.

- **PASS:** if the auxiliary battery positive cable has no damage **OR** only the conduit has damage, this cable passes inspection and needs to be re-routed. Proceed to **Auxiliary Battery Positive Cable Re-routing**.
- **FAIL:** If the auxiliary battery positive cable has damage to the wiring insulation, or the copper wiring within the cable is visible the cable requires replacement. Proceed to **Z-22-01-B - Auxiliary Battery Positive Cable Replacement**

INSPECTION PASS	INSPECTION FAIL
	
<p style="text-align: center;">IMPORTANT</p> <p>If damage to the conduit ONLY is present, wrap the area in abrasion-resistant electrical tape (Coroplast 837, 3M Scotch 22, or similar). Proceed to Z-22-01-A - Auxiliary Battery Positive Cable Re-routing.</p>	<p style="text-align: center;">STOP!</p> <p>If the auxiliary battery cable fails the inspection, proceed to Z-22-01-B - Auxiliary Battery Positive Cable Replacement.</p>

Z-22-01-A - AUXILIARY BATTERY POSITIVE CABLE RE-ROUTE

AUXILIARY BATTERY CABLE ROUTING OVERVIEW

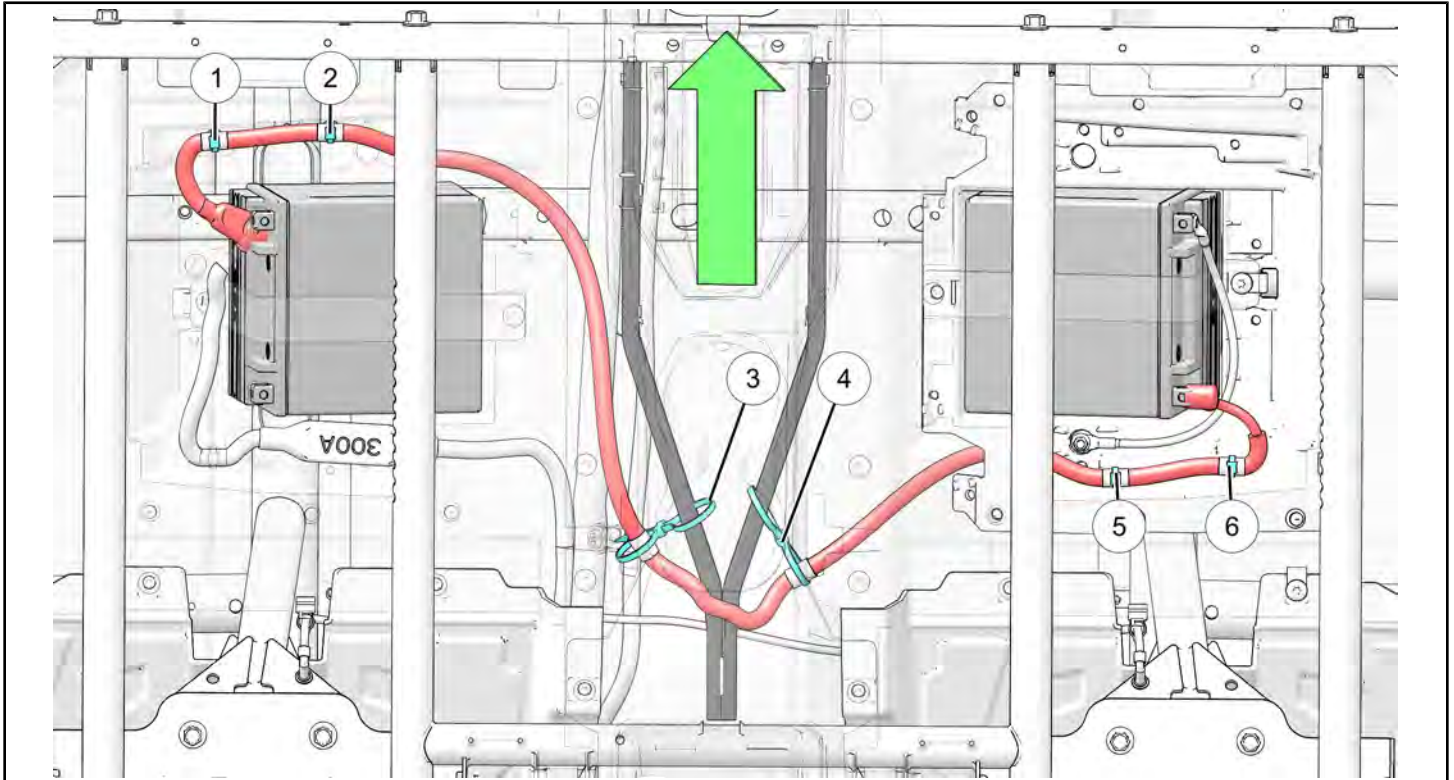

NOTICE

The green arrow is pointing towards the front of the vehicle.

AUXILIARY BATTERY CABLE ROUTING RETAINING POINTS

① Cable Tie / Push Clip

② Cable Tie / Push Clip

③ Double Loop Cable Tie Strap

④ Double Loop Cable Tie Strap

⑤ Cable Tie / Push Clip

⑥ Cable Tie / Push Clip

AUXILIARY BATTERY CABLE RE-ROUTING

1. Install the double loop cable tie retainers to the auxiliary battery cable in the routing locations ① and ②.

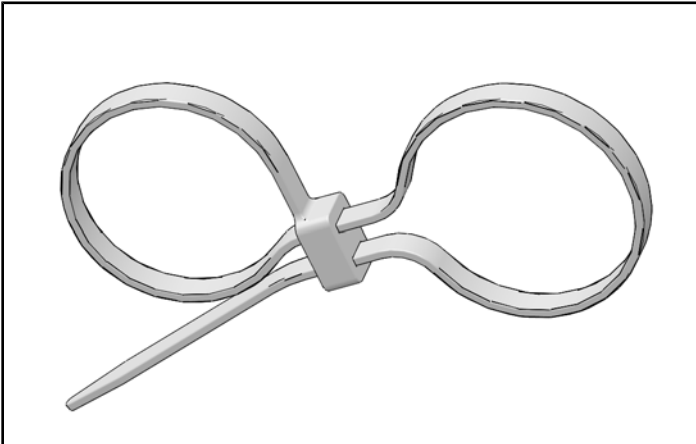

NOTICE

One loop of the cable tie will be installed to the auxiliary battery cable in locations ① and ②. The other side will be installed around the seat base bracket (wishbone brackets).



2. Starting from the drivers side route the cable over the seat base bracket (wishbone brackets) and under the PVT duct. Make sure the cable is routed in front of the accessory power port harness.

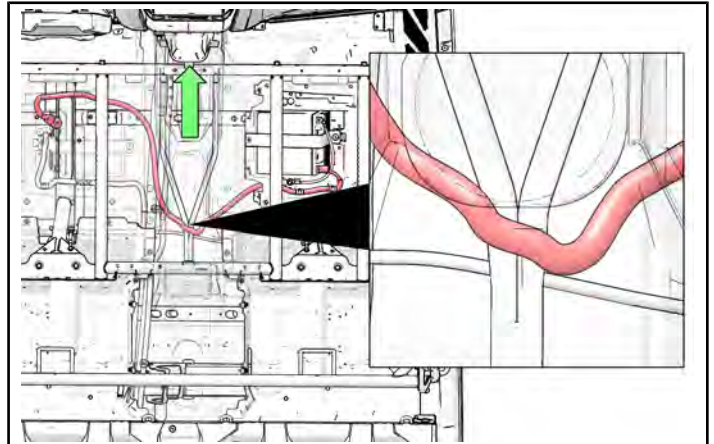

NOTICE

Image shown with the rear PVT duct removed for clarity. The PVT duct does not require removal to complete the procedure.

- Loosely install the remaining side of the double loop cable tie retainer to the front drivers and passenger seat base brackets under the center console in locations ① and ②. **DO NOT** fully tighten the cable ties until the cable has been fully routed.

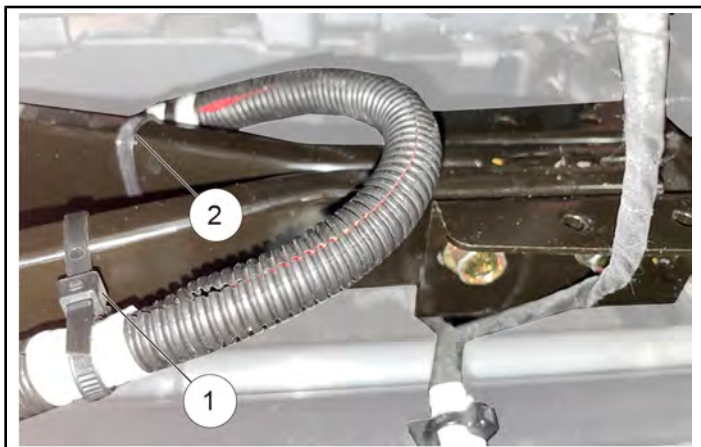

- Route the loose cable end through the grommet ① in the auxiliary battery compartment.

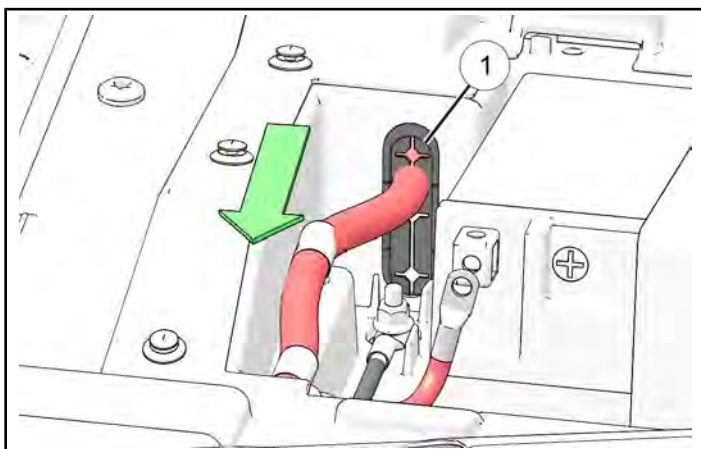

- Loosely install new cable ties on the routing clips in the auxiliary battery compartment.
- Route the cable to the battery connection and install the auxiliary battery cable protective boot on the positive battery cable.

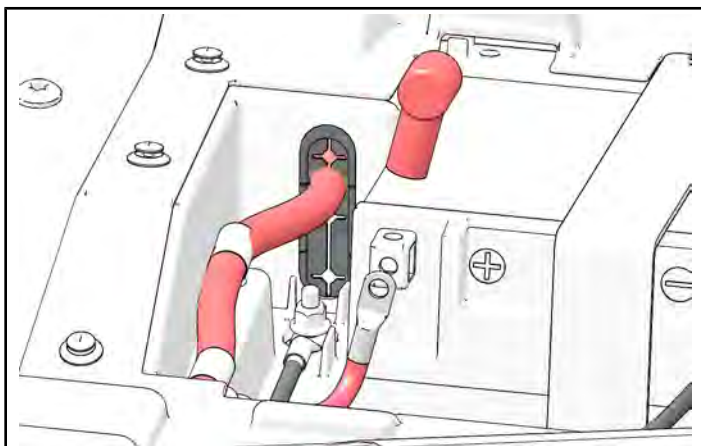

- Install the auxiliary positive battery cable, battery cable fastener, washer, and nut to the auxiliary battery. Torque to specification.

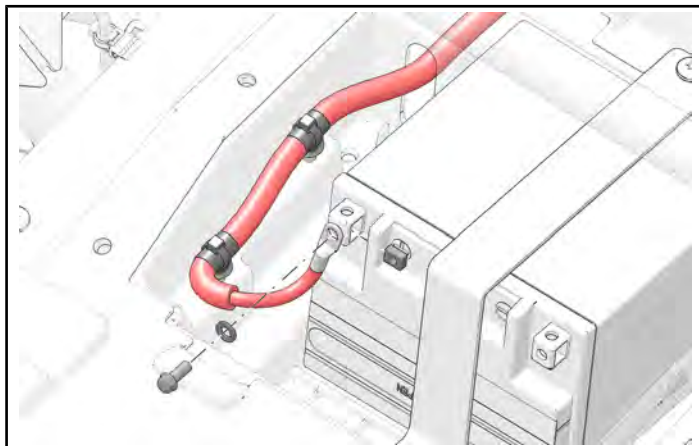

TORQUE

Battery Terminal Fastener:
44 in-lbs (5 N·m)

- After torquing the fastener, move the battery cable protective boot to cover the terminal.
- Make sure the auxiliary battery cable is routed properly before tightening the cable ties.

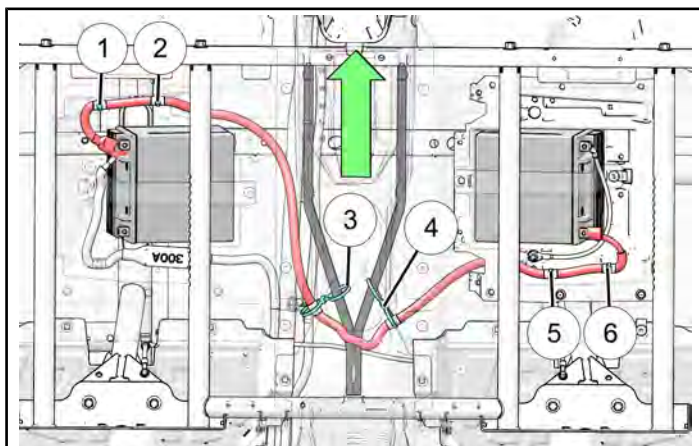

NOTICE

The green arrow is pointing towards the front of the vehicle.

- Tighten all cable ties installed on the auxiliary battery cable and routing locations.
- If cable ties were used to attach the front center console to the seat frame, remove the cable ties.

REAR CENTER CONSOLE INSTALLATION

1. Tip the rear center console forward and set down until the front edges of the console are past the seat belt mounts and seat frame, then bring the rear end of the console down.

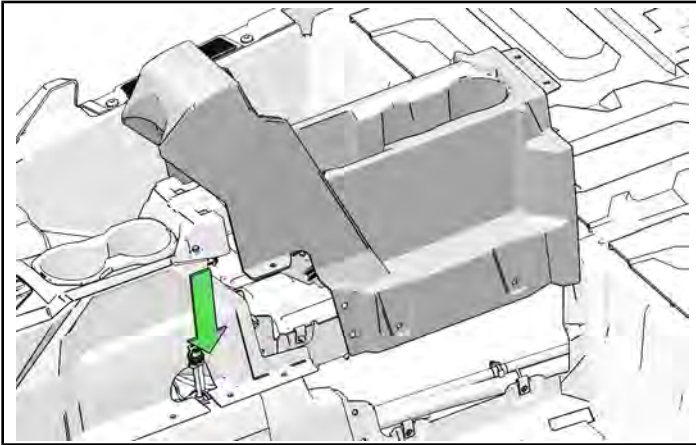

IMPORTANT

Make sure that the rear tab of the rear center console is installed under the rear seat panel.

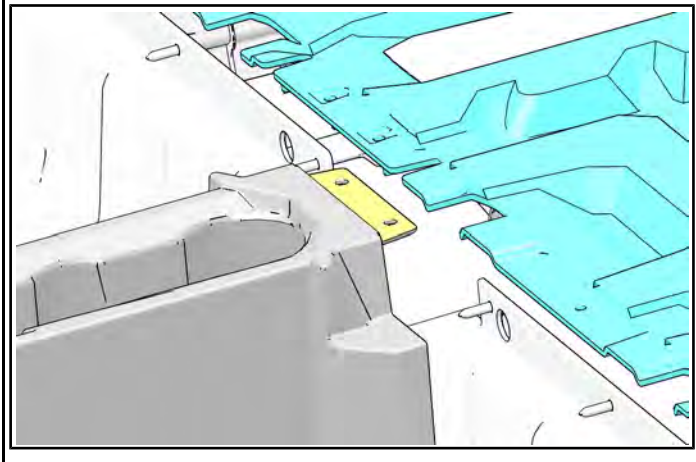

2. Install the torx fasteners ① on the left side of the rear center console. Torque the fasteners to specification.

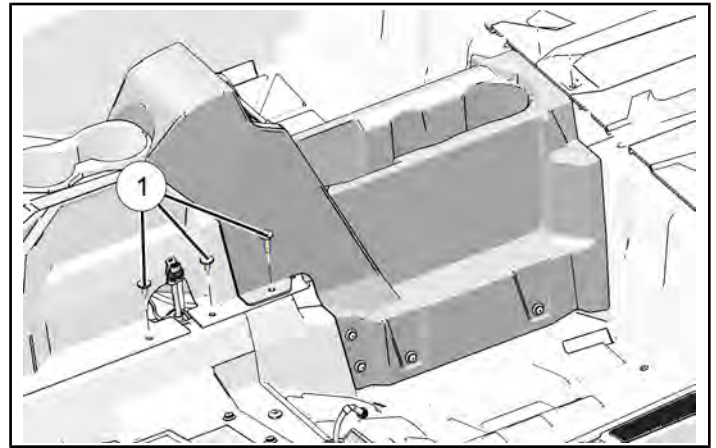

IMPORTANT

The rear torx fastener is longer than the other two. Make sure that the longer fastener is installed in the correct position.

TORQUE

Center Console Fasteners:
89 in-lbs (10 N·m)

3. Install the push rivets ② on the left side of the rear center console.

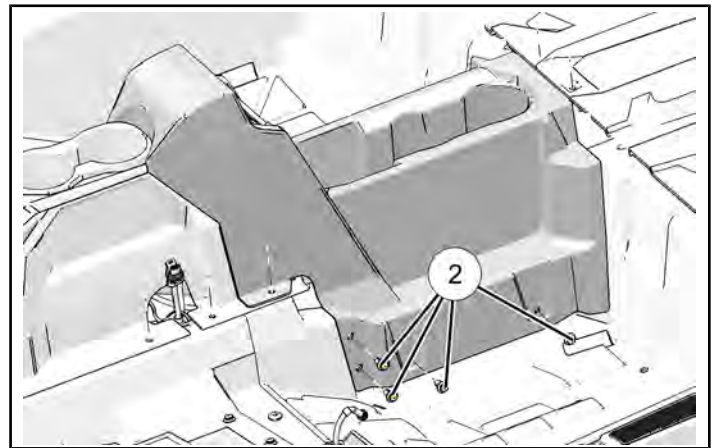

4. Repeat these steps for the right side of the rear center console.

5. Install the rear console net pocket storage compartment.

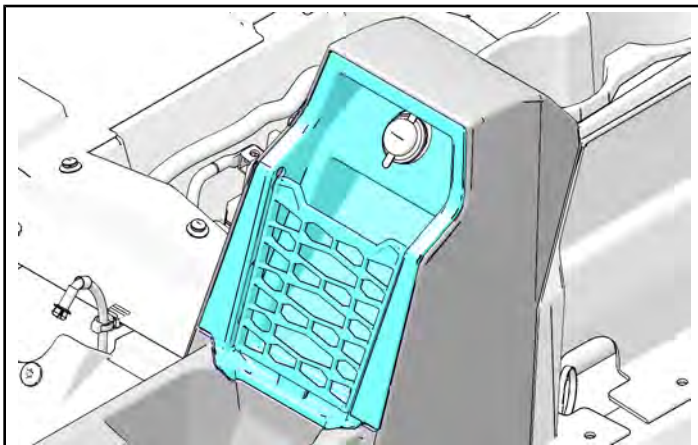

6. Install the fasteners under the rear seat. Torque the fasteners to specification.

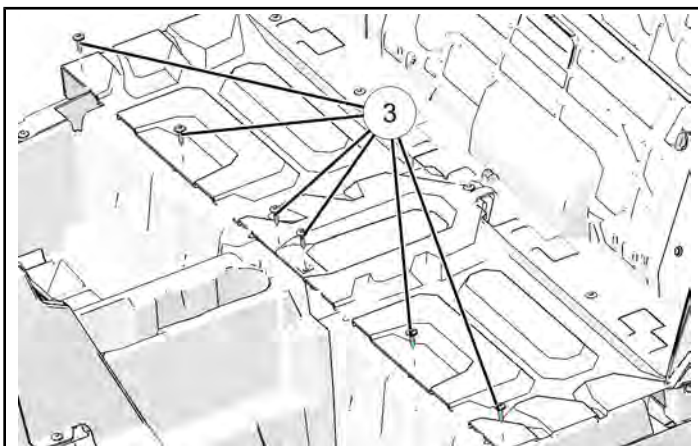

TORQUE

Rear Under-Seat Panel Fasteners:
89 in-lbs (10 N·m)

7. Buckle the rear seat, inner thigh belt clasps. Install the cotter pin.

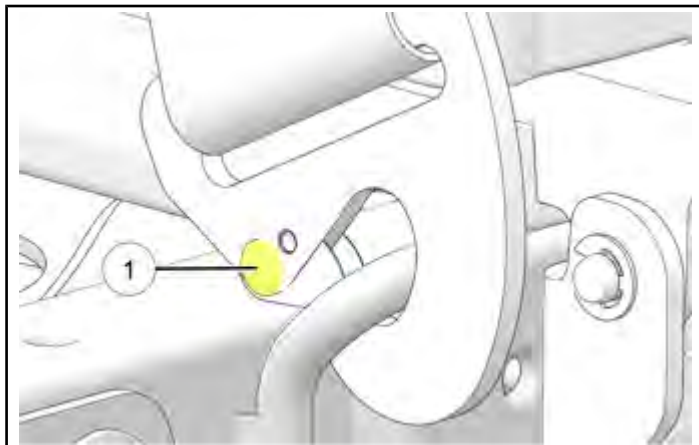

NOTICE

If a replacement cotter pin is required, a commercially available 7/64" x 7/8" cotter pin can be used.

8. Lower the rear seat bottoms and install the rear seat backs.

SEAT INSTALLATION / BATTERY CONNECTION

1. Connect the negative battery cables (black) in the following order. Install the negative battery terminal fastener and washer. Torque to specification.
 - a. Connect the primary battery (drivers side) negative cable.
 - b. Connect the auxiliary battery (passenger side) negative cable.

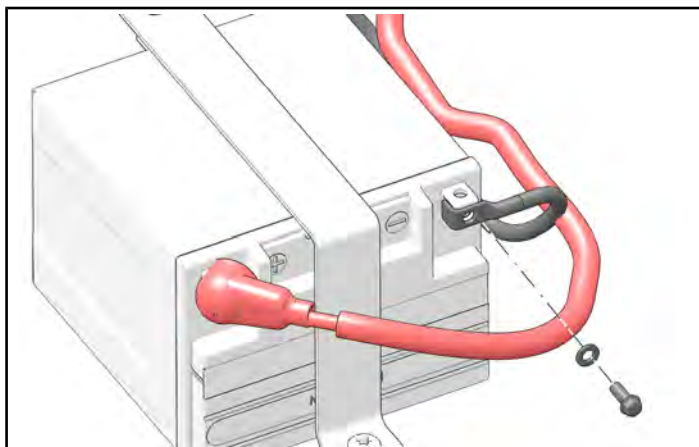

TORQUE

Battery Terminal Fastener:
44 in-lbs (5 N·m)

2. Make sure that all positive and negative battery cables are installed and torqued.

3. Remove the strap or bungee cord holding the seat in the upright position. Lower the seat onto rear receiver tubes.

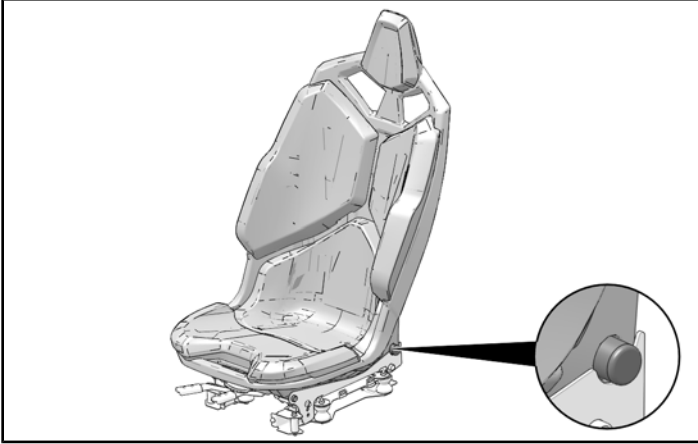

4. Repeat for the passenger seat.

FINAL STEPS

1. Key ON the vehicle and make sure that the vehicle powers up properly.
2. Submit a Service Bulletin claim for Z-22-01-A.

Z-22-01-B - AUXILIARY BATTERY POSITIVE CABLE REPLACEMENT

AUXILIARY BATTERY CABLE REPLACEMENT

STOP!

Only replace the auxiliary battery positive cable if damage was identified during the inspection procedure.

1. Remove the drivers front seat lap belt lower strap harness anchors.

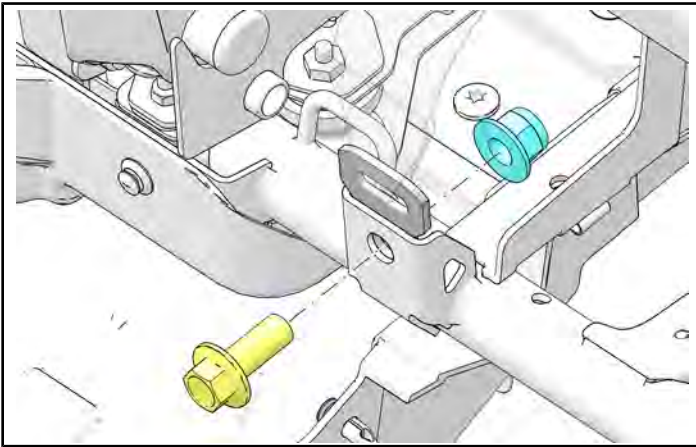
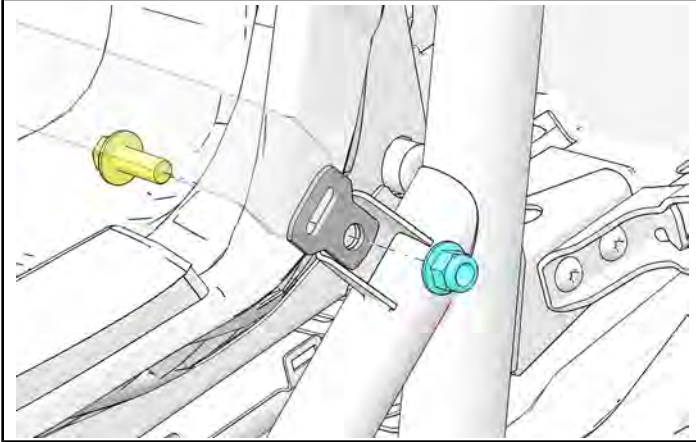

2. Remove the drivers front seat thigh belt lower strap harness anchors ② and ③.

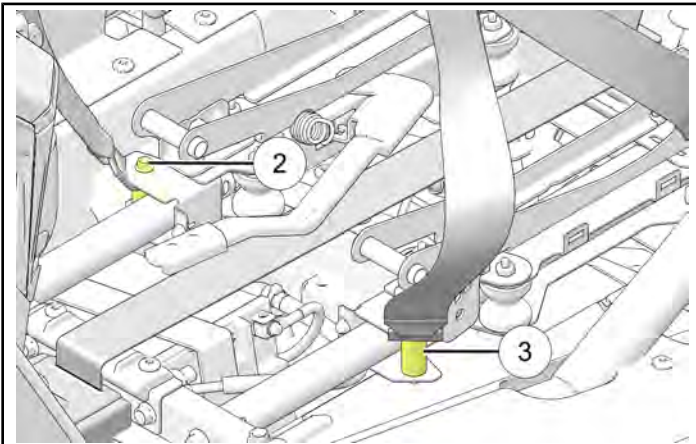

3. Route the seat belt harness straps through the drivers seat and disconnect the seat belt switch connector.
4. Remove the drivers seat from the vehicle.
5. Disconnect the positive battery cable (red) from the primary battery (drivers side). Make sure the protective boot is covering the cables after installation.

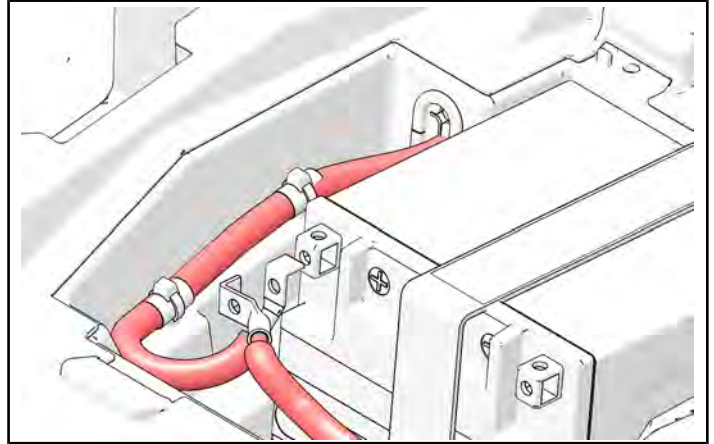

6. In the primary battery (drivers side) compartment, Remove and discard the primary battery positive cable clips ① from the battery box. The new auxiliary battery cable will come with new clips installed.

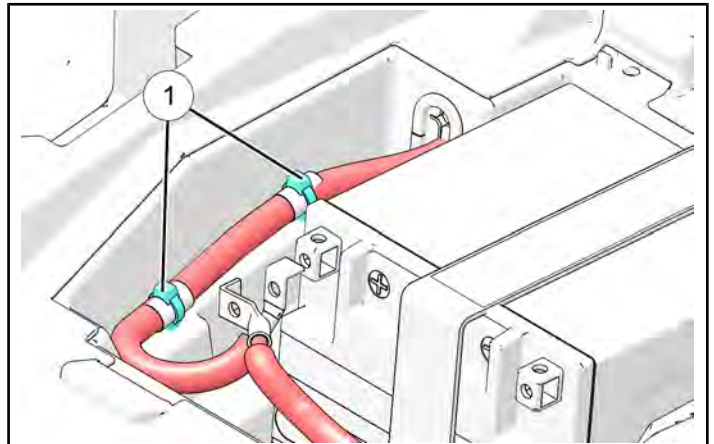

The information contained within this document is confidential and protected by U.S. and international copyright laws, and is the property of Polaris Inc. This document is provided for the sole use of authorized Polaris dealers and distributors. This document is not to be distributed, duplicated, or copied, digitally or otherwise, without the written consent of Polaris Inc.

7. Remove the fasteners from the fuse panel and move the fuse block to gain access to the push rivet under the fuse panel.

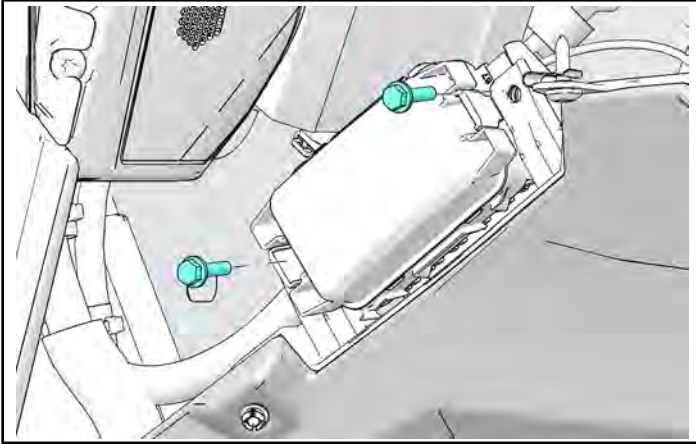

8. Remove the two push rivets near the fuse panel.

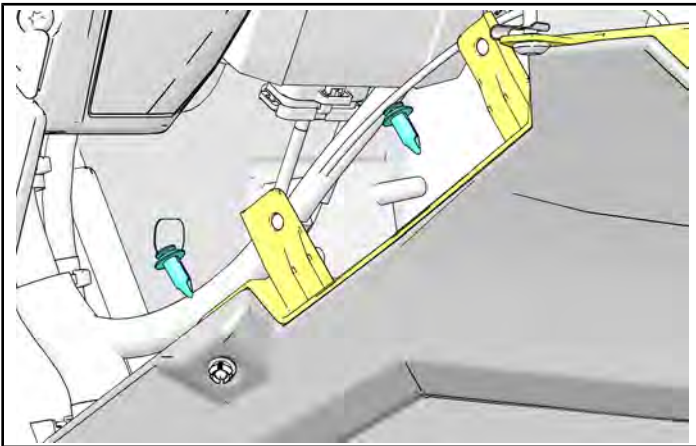

9. Remove the fastener attaching the drivers side center console fastener to the upper console panel.

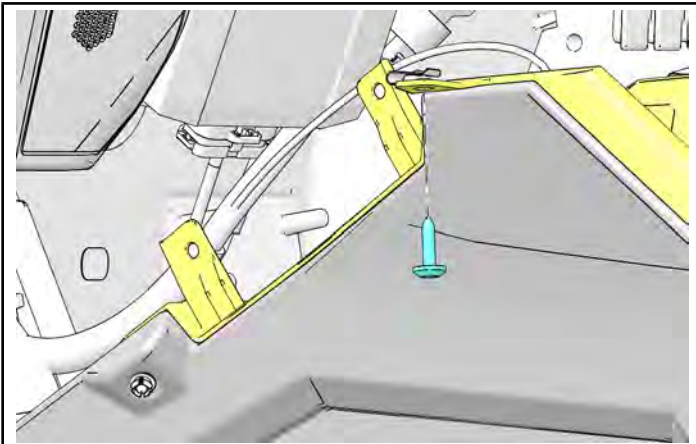

10. Remove the remaining fasteners from the drivers side center console panel.

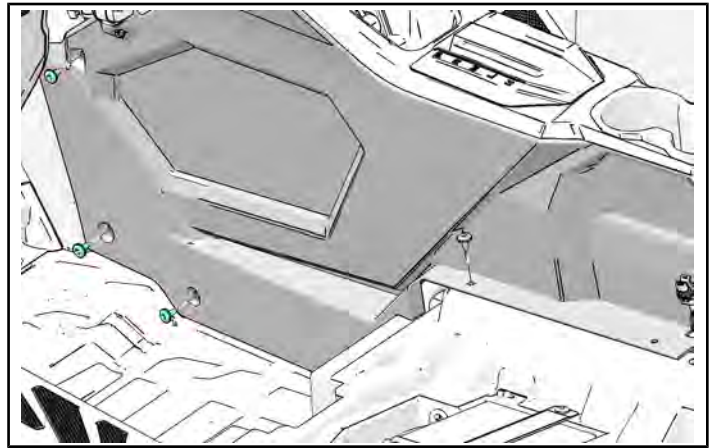

11. Remove the interior light from the center console panel.
12. Remove the drivers side center console panel from the vehicle.
13. Remove and discard the *OLD* auxiliary positive battery cable from the vehicle.

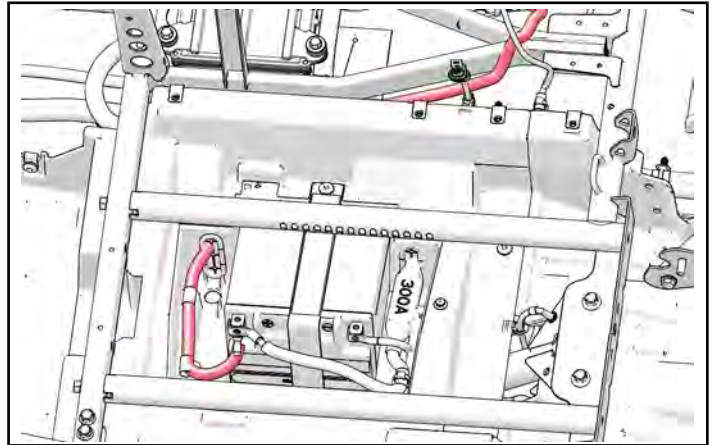

14. Install the *NEW* auxiliary battery cable. Start the routing from the drivers side battery.

IMPORTANT

The terminals are different on each end of the auxiliary positive battery cable. The bent terminal will be installed on the primary battery and flat terminal will be installed on the auxiliary battery.

15. Install the retaining clips ① and ② in the routing locations.

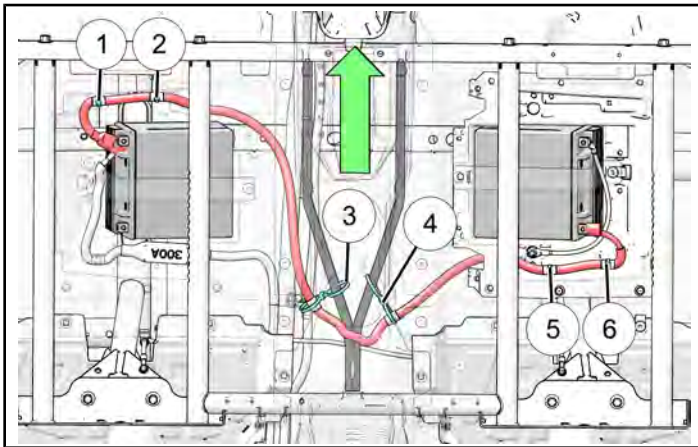

16. Starting from the drivers side route the cable over the seat base bracket (wishbone brackets) and under the PVT duct. Make sure the cable is routed in front of the accessory power port harness.



NOTICE

Image shown with the rear PVT duct removed for clarity. The PVT duct does not require removal to complete the procedure.

17. Loosely install the remaining side of the double loop cable tie retainer to the front drivers and passenger seat base brackets under the center console in locations ① and ②. **DO NOT** fully tighten the cable ties until the cable has been fully routed.

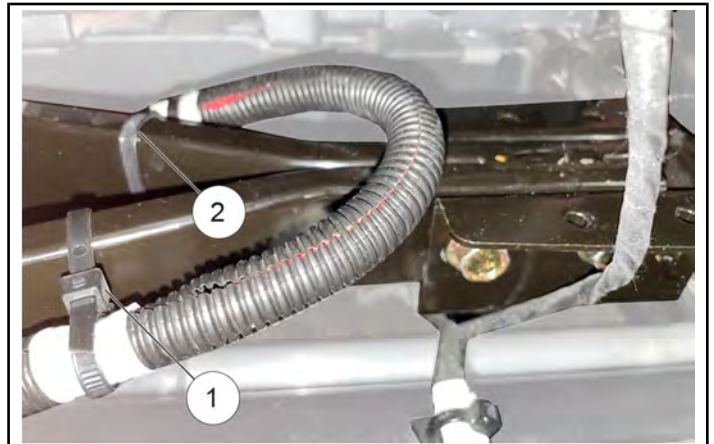

18. Route the loose cable end through the grommet ① in the auxiliary battery compartment.

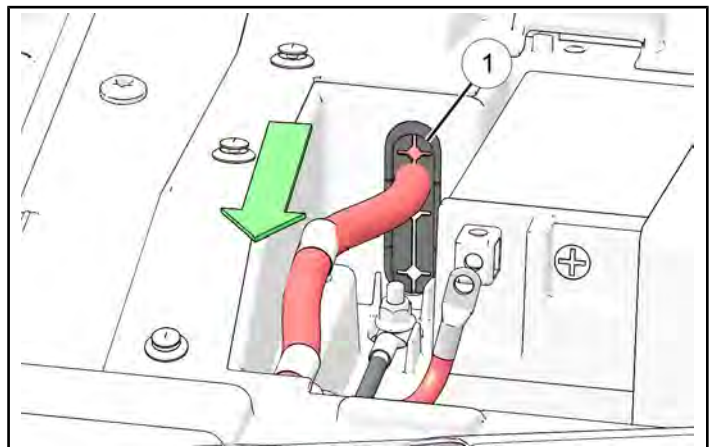

19. Retain the cable to the auxiliary battery box retaining clips ⑤ and ⑥ (installed on the cable) in the routing locations.

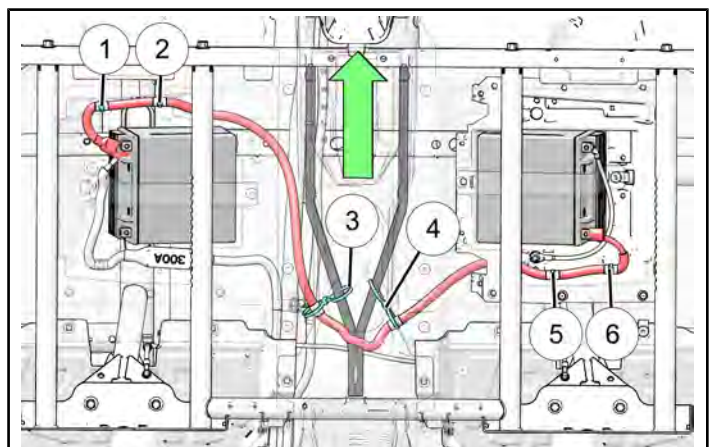

20. Route the cable to the battery connection. Install the auxiliary positive battery cable, battery cable fastener, washer, and nut to the auxiliary battery. Torque to specification.

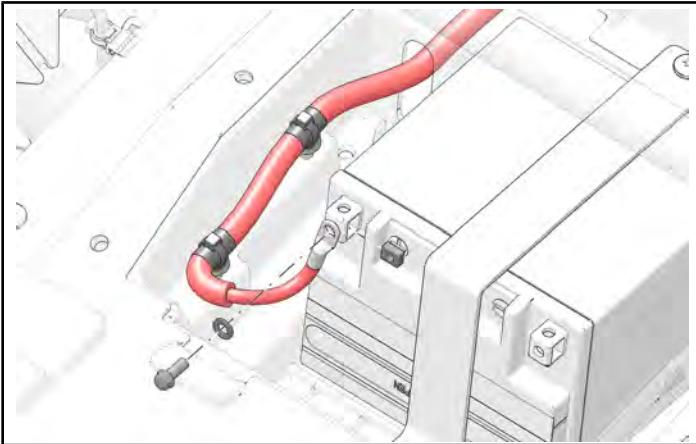

TORQUE

Battery Terminal Fastener:
44 in-lbs (5 N·m)

21. After torquing the fastener, move the battery cable protective boot to cover the terminal.

22. Make sure the auxiliary battery cable is routed properly before tightening the cable ties.

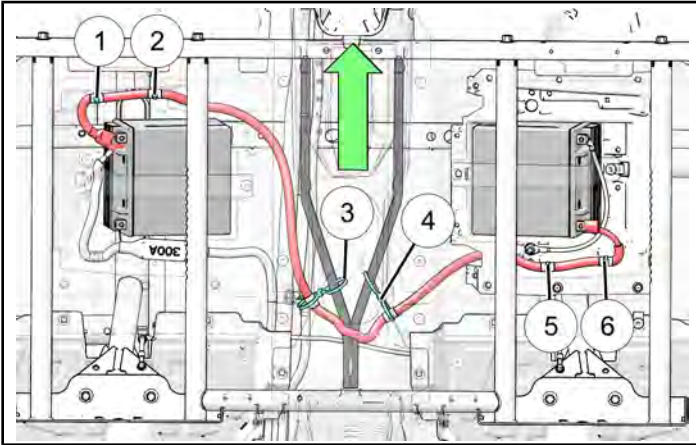

NOTICE

The green arrow is pointing towards the front of the vehicle.

23. Tighten all cable ties installed on the auxiliary battery cable and routing locations.

24. Connect the positive battery cable (red) on the primary battery. Torque the fastener to specification.

IMPORTANT

Make sure that the main battery cable and auxiliary battery cables are stacked as shown.

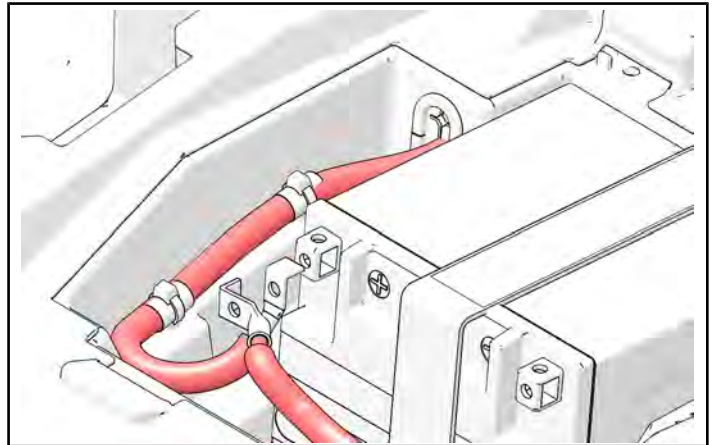

TORQUE

Battery Terminal Fastener:
44 in-lbs (5 N·m)

25. Connect the negative battery cables (black) in the following order. install the negative battery terminal fastener and washer. Torque to specification.

- a. Connect the primary battery (drivers side) negative cable.
- b. Connect the auxiliary battery (passenger side) negative cable.

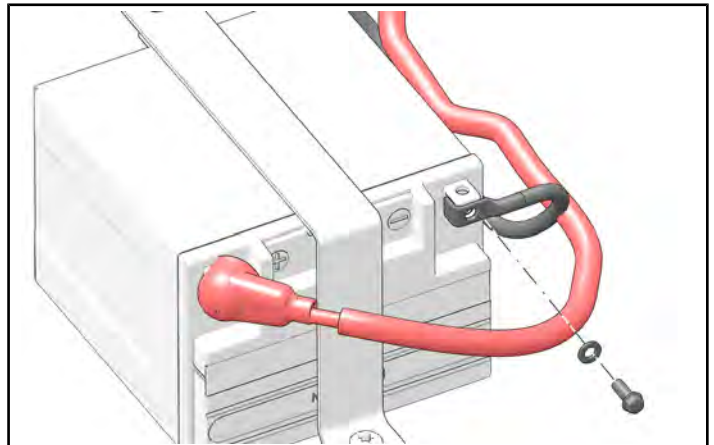

TORQUE

Battery Terminal Fastener:
44 in-lbs (5 N·m)

26. Make sure that all positive and negative battery cables are installed and torqued.

27. Install the drivers side center console panel on the vehicle.

28. Connect the interior light to the drivers side center console panel.

29. Install the two push rivets near the fuse panel.

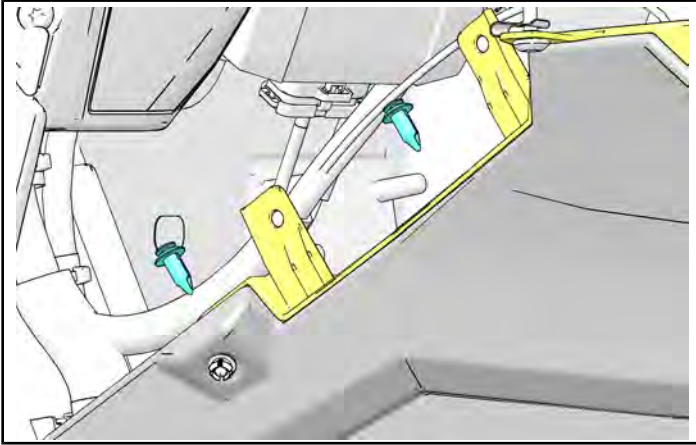

30. Install the fastener attaching the drivers side center console fastener to the upper console panel. Torque to specification.

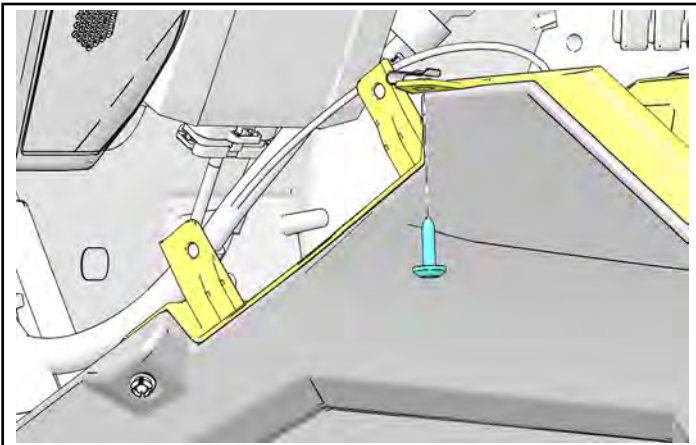

TORQUE

Center Console Fastener:
89 in-lbs (10 N·m)

31. Install the fuse block fasteners. Torque the fuse box fasteners to specification.

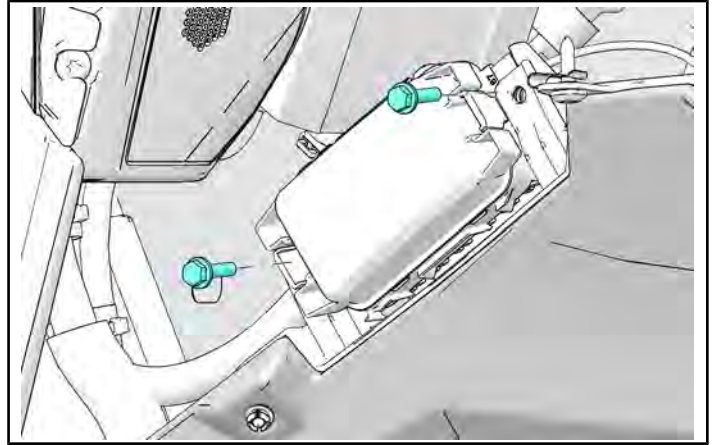

TORQUE

Fuse Block Fasteners:
31 in-lbs (3.5 N·m)

32. Install the center console fasteners in the drivers side center console panel. torque the fasteners to specification.

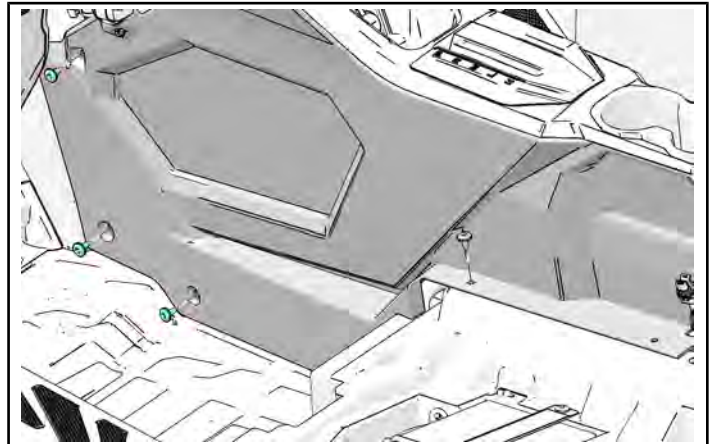

TORQUE

Center Console Fasteners:
89 in-lbs (10 N·m)

33. Install the rear center console.

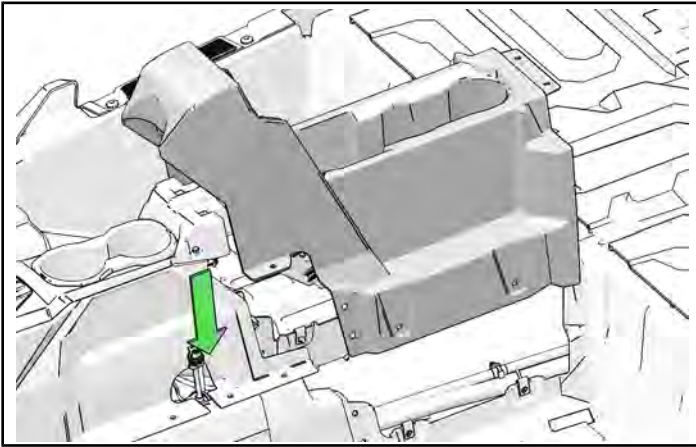

IMPORTANT

Make sure that the rear tab of the rear center console is installed under the rear seat panel.

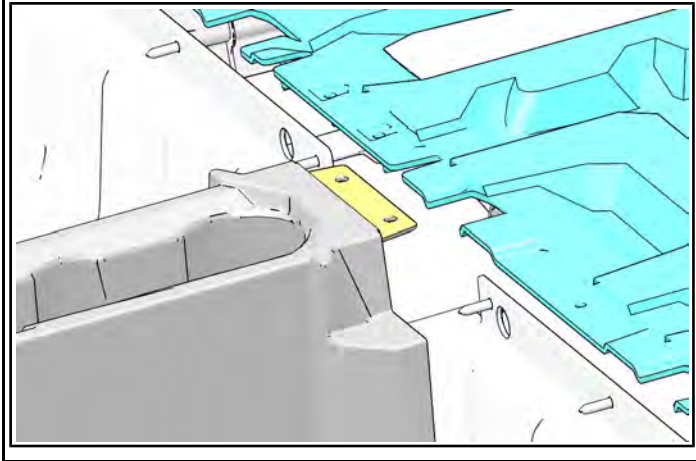

34. Install the torx fasteners ① on the left side of the rear center console. Torque the fasteners to specification.

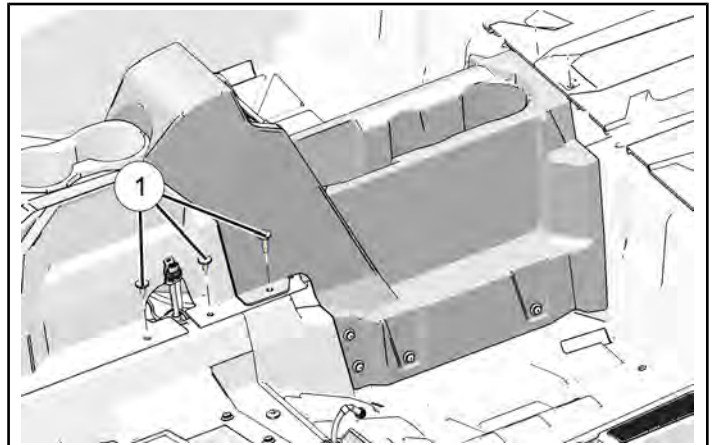

IMPORTANT

The rear torx fastener is longer than the other two. Make sure that the longer fastener is installed in the correct position.

TORQUE

Center Console Fasteners:
89 in-lbs (10 N·m)

35. Install the push rivets ② on the left side of the rear center console.

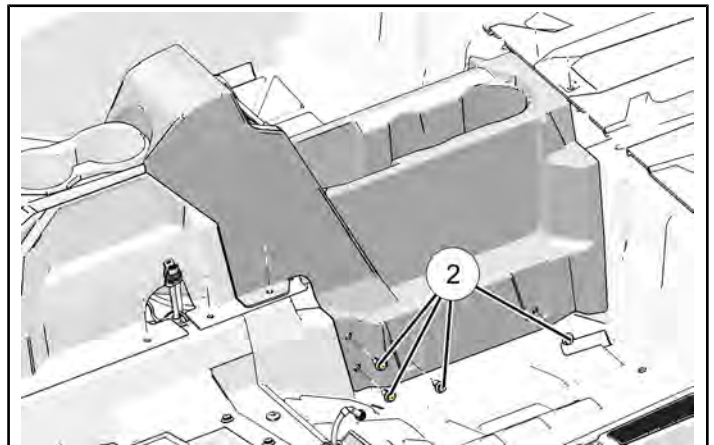

36. Repeat these steps for the right side of the rear center console.

37. Install the rear console net pocket storage compartment.

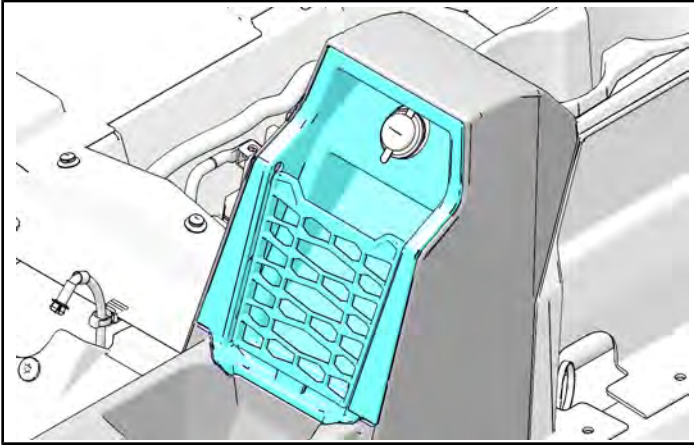

38. Install the fasteners under the rear seat. Torque the fasteners to specification.

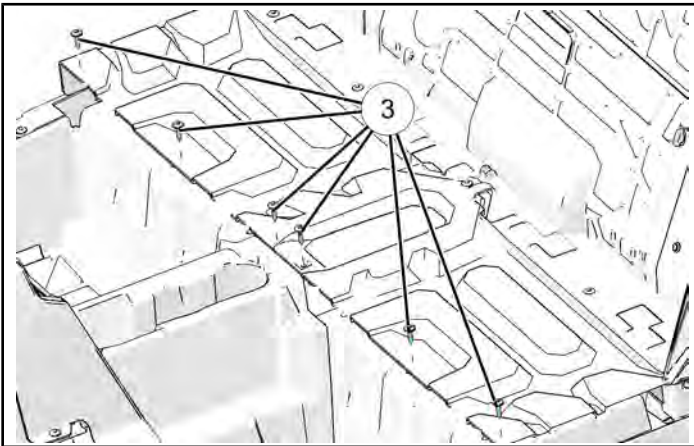

TORQUE

Rear Under-Seat Panel Fasteners:
89 in-lbs (10 N·m)

39. Buckle the rear seat, inner thigh belt clasps. Install the cotter pin.

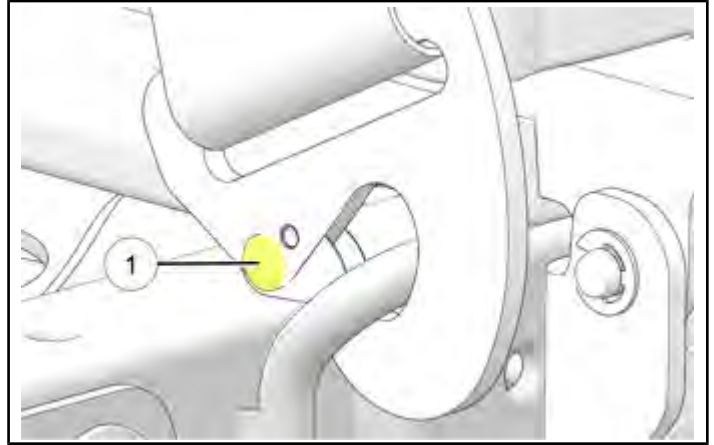

NOTICE

If a replacement cotter pin is required, a commercially available 7/64" x 7/8" cotter pin can be used.

40. Lower the rear seat bottoms and install the rear seat backs.

41. Route the seat belt harness straps through the drivers seat and install the drivers seat in the vehicle.

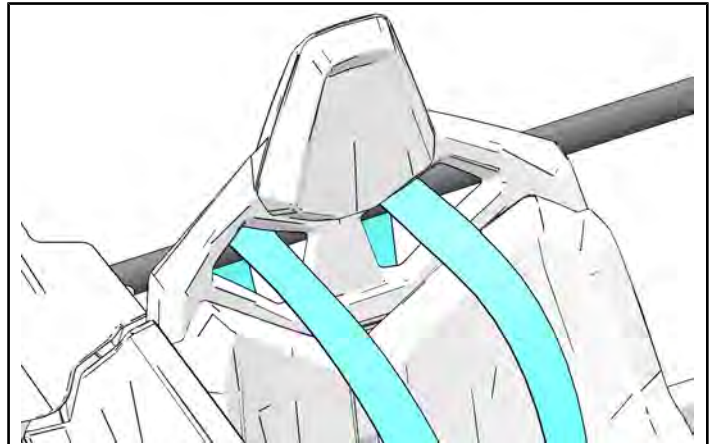

⚠ WARNING

Improper routing can cause the seat belt harness to fail, which can result in serious injury or death.

42. Install the drivers seat belt lower strap harness anchors. Torque to specification.

IMPORTANT

Make sure the fasteners are installed in the direction shown.

Make sure there are not twists in the seat belt harness before installing the fasteners.

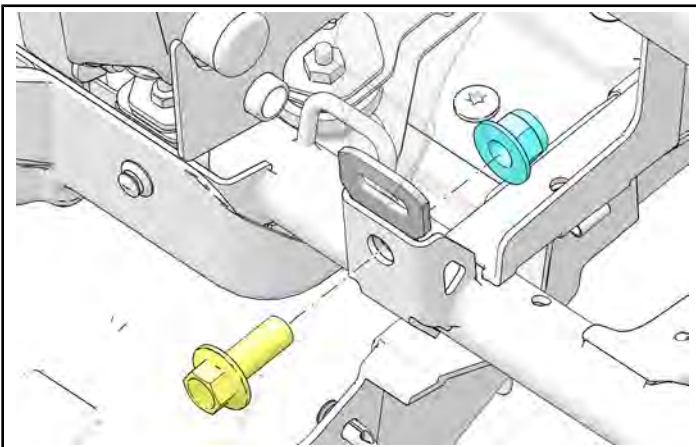
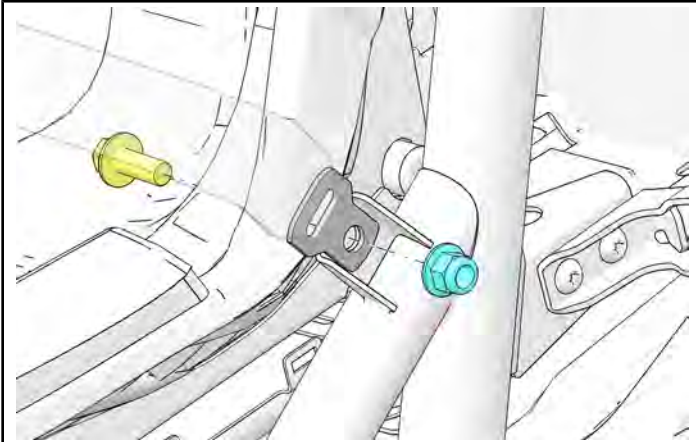

TORQUE

Front Seat Belt Harness Anchor Fasteners:
44 ft-lbs (60 N·m)

43. Stack front thigh belt harness brackets on top of each spacer groove.

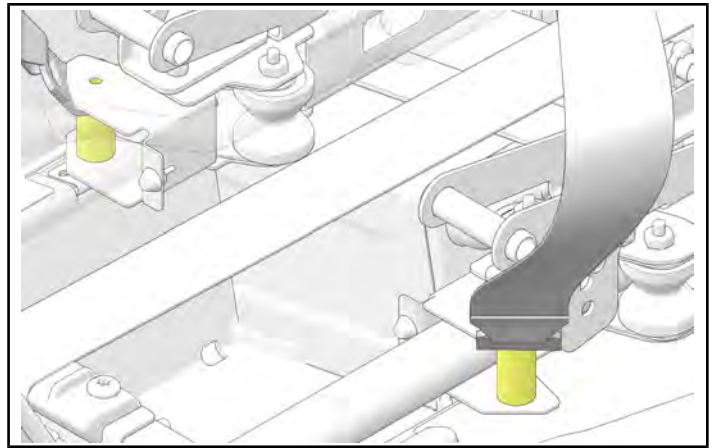

44. Install the front seat inner thigh belt strap anchors.

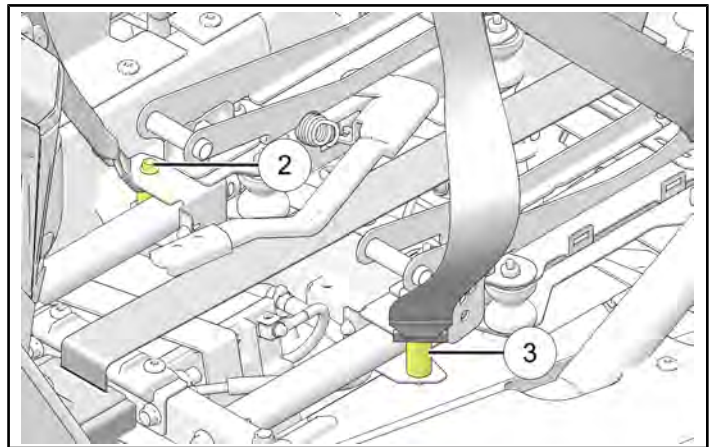

TORQUE

Front Seat Belt Harness Anchor Fasteners:
44 ft-lbs (60 N·m)

45. Connect the drivers seat belt switch electrical connector.

46. Remove the strap or bungee cord holding the passenger seat in the upright position. Lower the seat onto rear receiver tubes.

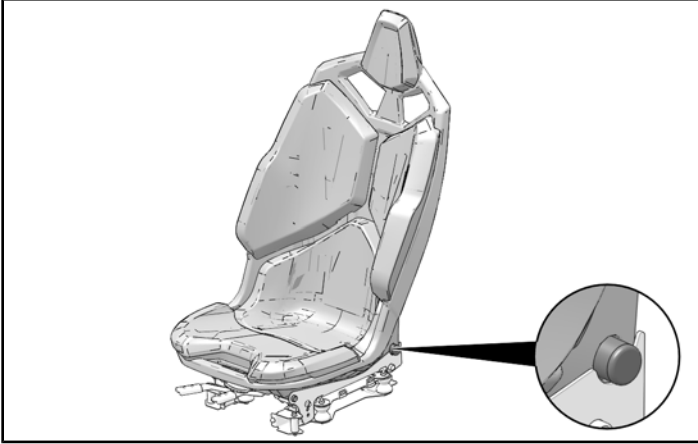

47. Turn the key to the ON position and make sure that the vehicle powers up properly.
48. Buckle the drivers front seat belt and make sure the seat belt warning light is not illuminated on the gauge cluster.
49. Submit a Service Bulletin claim for Z-22-01-B.



Polaris Industries Inc.
P.O. Box 47700
Medina, MN 55340-9960

IMPORTANT SAFETY / STOP RIDE NOTICE

This notice applies to your vehicle

**Subject: 2022 RZR Pro R 4 Premium and Ultimate Battery
Cable Routing**

PLEASE READ IMMEDIATELY

VIN: Z-22-01
First Name Last Name
Address
City, State ZIP

Dear Polaris Owner,

In cooperation with the U.S. Consumer Product Safety Commission (CPSC), Polaris is conducting a voluntary recall of some Model Year 2022 RZR Pro R 4 Premium and Ultimate vehicles. Our records indicate that you own one of these vehicles.

The reason for this notice:

Polaris is recalling these units because it has determined that some Model Year 2022 RZR Pro R 4 Premium and Ultimate vehicles may have an incorrectly routed auxiliary battery positive cable, which may contact the prop shaft during vehicle operation. Prolonged contact of the battery cable with the prop shaft may result in an electrical short, posing a fire hazard and risk of serious injury.

To resolve this concern, Polaris has developed a repair procedure to inspect and re-route the affected battery cable. In limited cases where the cable insulation has been damaged, replacement of the auxiliary battery connection cable may be required. This work will be performed by your dealer at no cost to you.

What you should do:

Immediately stop using the vehicle, and schedule an appointment with an authorized Polaris dealer. Do not attempt to repair it yourself. These repairs must be done only by an authorized Polaris dealer.

DO NOT OPERATE YOUR VEHICLE UNTIL THIS SAFETY RECALL HAS BEEN COMPLETED BY YOUR DEALER.

If you need assistance contacting or locating a Polaris dealer, or if you have questions your Polaris dealer is not able to address, contact our Polaris Owner Connections Department at 1-800-POLARIS (765-2747), scan the QR code, or go to <https://www.polaris.com/en-us/self-help/>.



What your dealership will do:

Authorized dealers will be inspecting and re-routing or replacing the auxiliary battery cable on the affected vehicle at no cost to you. This repair should take approximately 60 minutes. They have been instructed to repair your vehicle.

If you received this notice in error:

This notice was mailed to you according to our most current registration information. If you no longer own this vehicle, or if some of the contact information in this notice is incorrect, please contact your dealer to complete a transfer of ownership. Federal law requires that any vehicle lessor receiving this notice must forward a copy of this notice to the lessee within 10 working days after the day on which the notice is received.

We apologize for this inconvenience and assure you that we are committed to customer satisfaction and providing world-class products for riders to enjoy.

Sincerely,

Polaris Off-Road Vehicles

For the latest updates to this safety recall, or to check if your vehicle is part of another safety recall, scan the QR code, or go to www.polaris.com/en-us/off-road-recalls/.





IMPORTANT SAFETY / STOP RIDE NOTICE

This notice applies to your vehicle

Recall Campaign: **2022-165**

Subject: **2022 RZR Pro R 4 Premium and Ultimate Battery Cable Routing**

PLEASE READ IMMEDIATELY

Polaris Industries Inc.
P.O. Box 47700
Medina, MN 55340-9960

VIN: Z-22-01
First Name Last Name
Address
City, State ZIP

Dear Polaris Owner,

This notice is sent to you in accordance with the requirements of the *Motor Vehicle Safety Act*. This is to inform you that your vehicle may contain a defect that could affect the safety of a person. Our records show you have purchased a Model Year 2022 RZR Pro R 4 Premium or Ultimate off-road vehicle.

The reason for this notice:

Polaris is recalling these units because it has determined that some Model Year 2022 RZR Pro R 4 Premium and Ultimate vehicles may have an incorrectly routed auxiliary battery positive cable, which may contact the prop shaft during vehicle operation. Prolonged contact of the battery cable with the prop shaft may result in an electrical short, posing a fire hazard and risk of serious injury.

To resolve this concern, Polaris has developed a repair procedure to inspect and re-route the affected battery cable. In limited cases where the cable insulation has been damaged, replacement of the auxiliary battery connection cable may be required. This work will be performed by your dealer at no cost to you.

What you should do:

Immediately stop using the vehicle, and schedule an appointment with an authorized Polaris dealer. Do not attempt to repair it yourself. These repairs must be done only by an authorized Polaris dealer.

DO NOT OPERATE YOUR VEHICLE UNTIL THIS SAFETY RECALL HAS BEEN COMPLETED BY YOUR DEALER.

If you need assistance contacting or locating a Polaris dealer, or if you have questions your Polaris dealer is not able to address, contact our Polaris Owner Connections Department at 1-800-POLARIS (765-2747), scan the QR code, or go to <https://www.polaris.com/en-ca/self-help/>.



What your dealership will do:

Authorized dealers will be inspecting and re-routing or replacing the auxiliary battery cable on the affected vehicle at no cost to you. This repair should take approximately 60 minutes. They have been instructed to repair your vehicle.

We apologize for this inconvenience and assure you that we are committed to customer satisfaction and providing world-class products for riders to enjoy.

Sincerely,

Polaris Off-Road Vehicles

For the latest updates to this safety recall, or to check if your vehicle is part of another safety recall, scan the QR code, or go to www.polaris.com/en-ca/off-road-recalls/.



This notice was mailed to you according to our most current registration information. If you no longer own this vehicle, or if some of the contact information in this notice is incorrect, please contact your dealer to complete a transfer of ownership. Federal law requires that any vehicle lessor receiving this notice must forward a copy of this notice to the lessee within 10 working days after the day on which the notice is received.

Polaris Industries Ltd.
Consumer Service Department
50 Prairie Way
Winnipeg, MB, CA R2J – 3J8

Ref: Z2201