



# SAFETY BULLETIN

Release Date: May 07, 2019

## IND

Communication #: I-19-02-A/B/C

Model Year(s): 2014-2020

— Confidential and Proprietary —

### VERSION: R04 (August 29, 2022)

*\*\*2015-2020 Heavyweight Air Cooled motorcycles added to the affected population. Part C has also been added for vehicles that have the VCM reflash completed as part of a different campaign. Reference Unit Inquiry to ensure all affected motorcycles are identified and repaired per this Safety Bulletin\*\**

### **IMPORTANT STOP SALE SAFETY NOTICE!**

**Stop selling affected vehicles immediately until the repair procedure has been completed on affected units at your dealership. Federal law prohibits the sale of products subject to a recall. Selling such products could subject the seller to substantial penalties.**

#### IMPORTANT

If you are working with a printed copy, please verify you have the most current version of this document.

## SUBJECT: INDIAN MOTORCYCLE - FORWARD LIGHTING

### PURPOSE

Indian Motorcycle has determined that an electrical defect may exist in 2014-2020 Heavyweight Air Cooled Indian Motorcycles, resulting in the unexpected loss of forward lighting. This defect may also cause heat damage to the Vehicle Control Module (VCM) and Pin 11 of the center VCM connector.

Indian Motorcycle has released this bulletin with instructions to inspect the VCM connector for damage, update the VCM software, and replace the VCM and pin 11 connector if damaged.

## AFFECTED MODELS

MODEL YEAR	MODELS	VEHICLE IDENTIFICATION NUMBER RANGE
2014	Chief Classic, Chief Vintage, Chieftain	Reference Unit Inquiry on the dealer website or the Service Bulletin list on the STOP site to lookup affected VINs.
2015	Chieftain, Chief Classic, Chief Vintage	
2016	Chieftain, Springfield, Chief Vintage	
2017	Chief Vintage, Chieftain, Chieftain Dark Horse, Chieftain Limited, Chieftain Elite, Springfield	
2018	Chief Vintage, Chieftain, Chieftain Classic, Chieftain Dark Horse, Chieftain Limited, Chieftain Elite, Springfield	
2019	Chief Vintage, Chieftain Classic, Springfield, Springfield Dark Horse	
2020	Chief Vintage, Springfield	

### IMPORTANT

Vehicles that had ISA-19-02 performed as an interim solution are still required to have this updated repair solution performed. Reference Unit Inquiry to determine if a VIN is affected.

## CUSTOMER NOTIFICATION

Dealers are required to review their sales records and make arrangements with customers for Bulletin completion. In addition to consumer units, dealers are required to correct any affected units in their inventory. Indian Motorcycle will be mailing a notification letter to consumers affected by this Bulletin. Indian Motorcycle will also send an email to owners for whom Polaris has a valid email address.

## WARRANTY CLAIM PARTS INFORMATION

Bulletin parts are excluded from the standard RMA policy and cannot be returned. An Initial Recommended Order Quantity has not been provided for this bulletin. For more details, refer to University of Polaris training course "Polaris Item Availability and Daily Ordering" and click on "Bulletin Ordering Training".

### NOTICE

Training required for this bulletin is carried forward from the original release in May, 2019. If your dealership personal is still certified, you will NOT need to retake the training.

### NOTICE

- Certain motorcycles will already have the latest VCM software installed and will not require a reflash. These motorcycles will have their VINs applied to PART C and PART B if damage is found.
- The motorcycles that DO NOT have up to date VCM software will only be applied to PART A and PART B if damage is found.

### VCM CONNECTOR INSPECTION & VCM REFLASH

<b>Bulletin #</b>	I-19-02-A
<b>Claim Type</b>	SB (Service Bulletin)
<b>Labor Allowance</b>	0.6 hours (36 minutes)
<b>Part Number / Description</b>	0000541 (QTY 1) Bulletin Misc Labor
<b>Parts Availability</b>	NA
<b>University of Polaris Training Required</b>	Yes <sup>1</sup>

<sup>1</sup>Polaris requires one person from a dealership to be certified before parts ordering may occur and two people from a dealership to be certified before warranty claims may be processed.

### VCM & CONNECTOR REPLACEMENT

<b>Bulletin #</b>	I-19-02-B
<b>Claim Type</b>	SB (Service Bulletin)
<b>Labor Allowance</b>	1.0 hours (60 minutes)
<b>Part Number / Description</b>	<i>Additional parts and labor required to complete I-19-02-B to be authorized through an ASK Polaris case.</i>
<b>Parts Availability</b>	Available to order when directed by ASK Polaris

### VCM CONNECTOR INSPECTION

<b>Bulletin #</b>	I-19-02-C
<b>Claim Type</b>	SB (Service Bulletin)
<b>Labor Allowance</b>	0.3 hours (18 minutes)
<b>Part Number / Description</b>	0000541 (QTY 1) Bulletin Misc Labor
<b>Parts Availability</b>	NA
<b>University of Polaris Training Required</b>	Yes <sup>1</sup>

<sup>1</sup>Polaris requires one person from a dealership to be certified before parts ordering may occur and two people from a dealership to be certified before warranty claims may be processed.

## ACCESSORY LABOR

Polaris will cover labor for the removal and installation of accessories required to complete the bulletin work. Follow the steps below to obtain reimbursement.

1. Start a new Ask Polaris Case, Service & Warranty Question > Authorization Request: In Warranty or Polaris ESC or Authorization Request: Out of Warranty/Goodwill.
2. Enter your contact information and VIN, along with miles and hours into the applicable fields.
3. Enter Indian Motorcycle® I-19-02 in the CONCERN and CAUSE fields. In the CORRECTION field, enter "ACCESSORY REMOVAL AND INSTALLATION".
4. Enter warranty fail codes 127/277/132.
5. Add part 0000541, quantity 1.
6. Attach photos of the vehicle and accessories sufficient to support the labor time requested.
7. Submit the case to Polaris.

## COVERAGE PERIOD

Coverage began on March 3rd, 2020. This bulletin has no expiration date.

## PARTS RETURN / DISPOSAL INFORMATION

Under no circumstances shall the parts removed be re-used, sold, or re-purposed for another application. It is your dealership / distributor's responsibility to make sure every part replaced (related to this communication) is taken out of circulation and disposed of properly or returned to Polaris (if required).

## SPECIAL TOOLS

- **US and Canada Dealers:** The special tool outlined in Part B of this Bulletin (PF-52576) was direct-shipped to dealers in February of 2018 for use with I-18-01. If additional or replacement tools are needed, they can be ordered through Bosch Automotive Service Solutions, by phone at 1-800-345-2233 or on-line via your dealer website at <https://polaris.service-solutions.com/>.
- **International Dealers:** The special tool outlined in this Bulletin (PF-52576) must be ordered through the Bosch Service Solutions website. File a Part Stock warranty claim for tool reimbursement.

# I-19-02-A / C VCM PIN INSPECTION

## TOOLS REQUIRED

- Digital Wrench® II
- Multilink XP cable
- Battery Tender (minimum 2 amps)
- 5 mm Allen Wrench
- 6 mm Allen Wrench
- In-lb Torque Wrench
- Phillips Screwdriver

# I-19-02-A / C VEHICLE CONTROL MODULE (VCM) CONNECTOR PIN 11 INSPECTION

## PREPARATION

### IMPORTANT

In the event the following inspection does reveal damage to Pin 11 of the center VCM connector (harness side), start an ASK Polaris case for further instruction as outlined in the I-19-02-B section of this document.

1. Park the motorcycle on a lift table with the wheel clamped in a wheel vise.
2. Turn the ignition off.
3. Remove Accessory Trunk, if applicable.
  - Remove the left and right saddlebags and remove the trunk lock fastener ⑤ from each trunk latch.

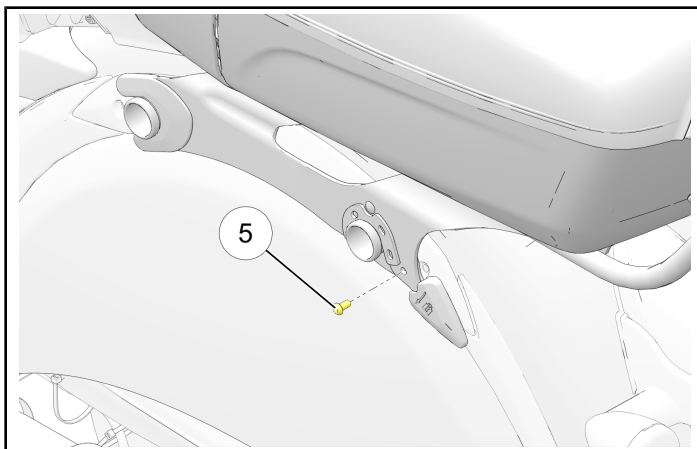

- Disconnect the trunk harness multi-plug ④.

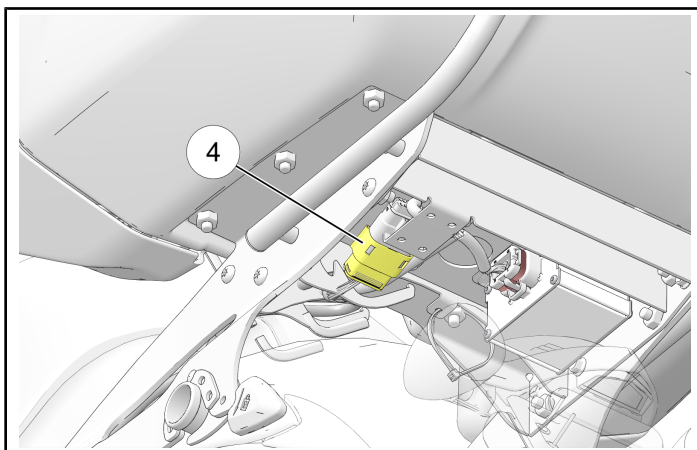

- Lift the trunk latches ③ to unlock the trunk from the mount.

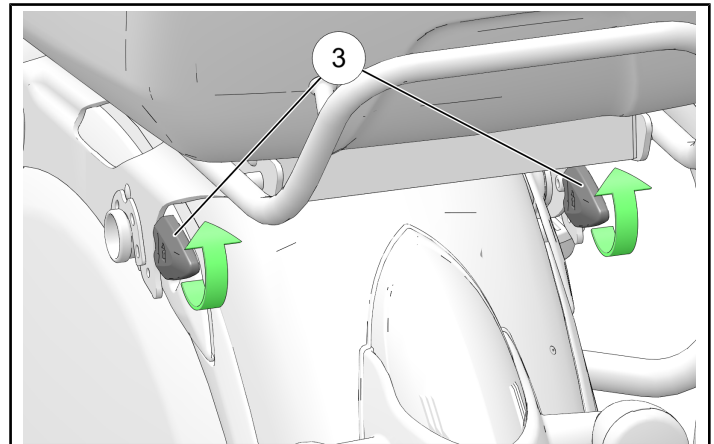

- Lift up on the rear of the trunk ④ and slide rearward ⑤ to release the trunk from the motorcycle.

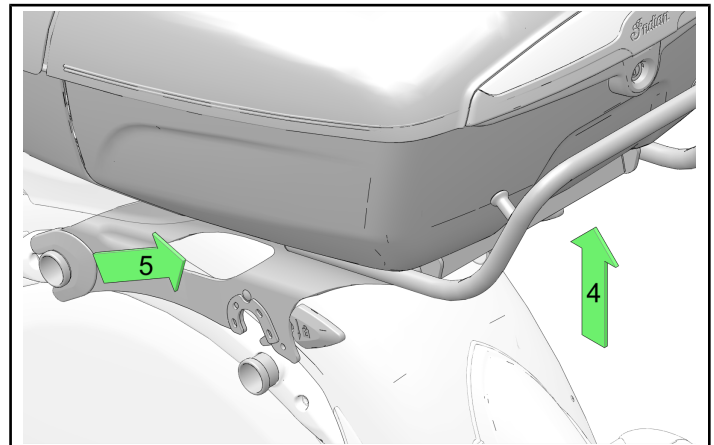

4. Pull carefully on the side panels to release the retaining posts from the in-frame grommets.

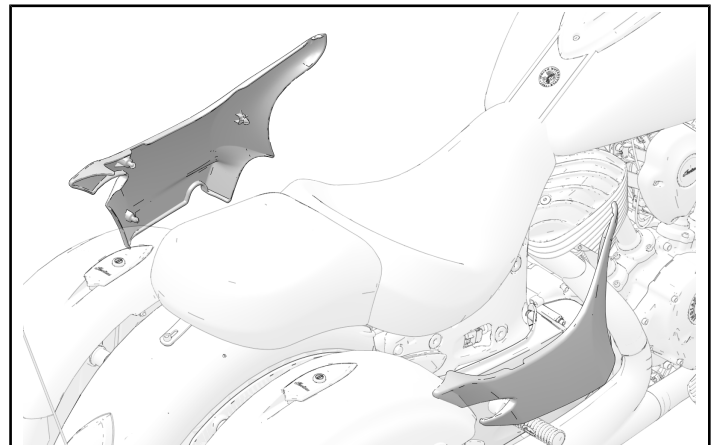

5. Using a 5 mm Allen Wrench, remove the rear seat fastener ②.

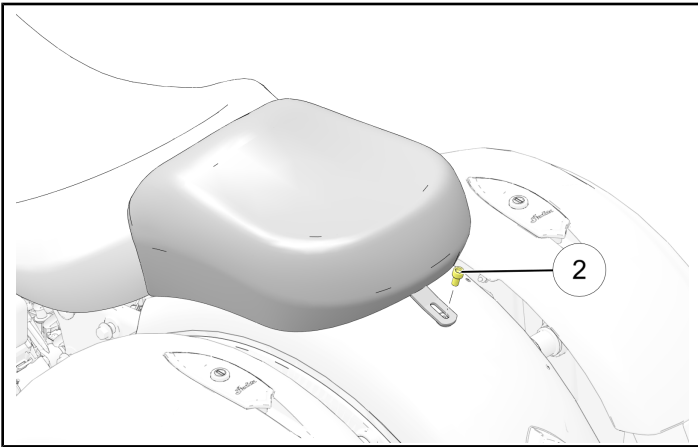

6. Using a 6 mm Allen Wrench, remove the two fasteners ① securing the seat to the frame.

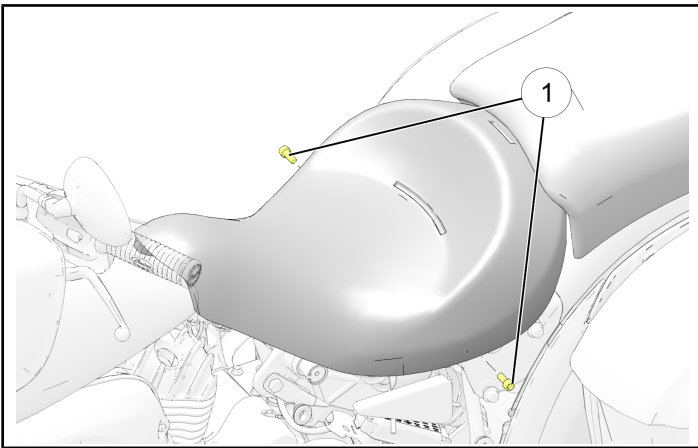

7. Lift the rear of the seat and pull rearward to disengage the front retaining arms from the bracket behind the fuel tank.

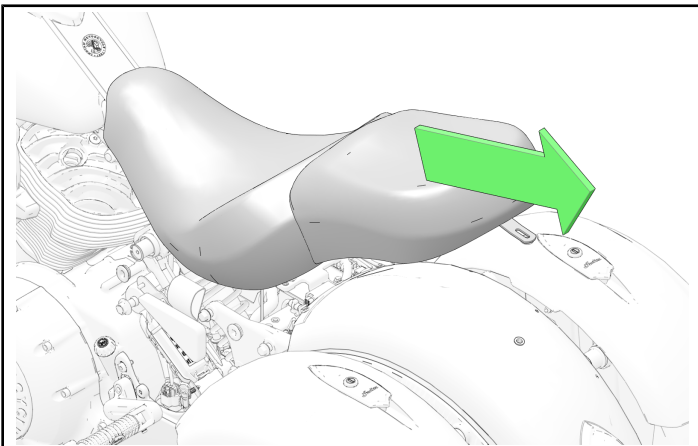

8. Place the seat upside down on a smooth, clean surface.

## VCM CONNECTOR PIN 11 INSPECTION

1. Find the VCM located on top of the battery box.

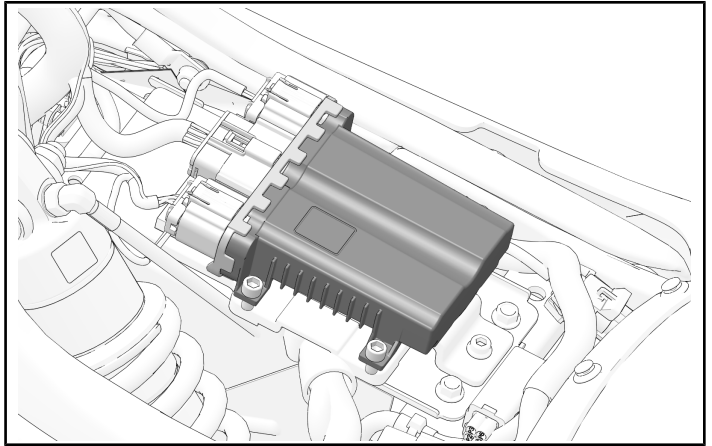

2. Disconnect the center connector on the VCM. Locate Pin 11 of the VCM1 (center) connector and check for any discoloration.

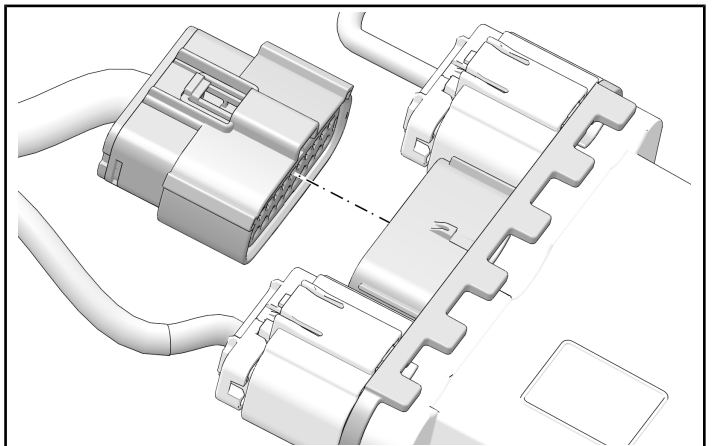

Inspect the male pin on the VCM board for damage.

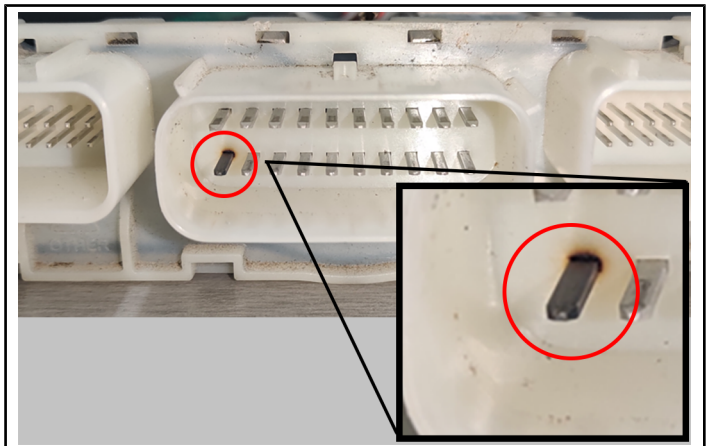

**IMPORTANT**

Pay special attention to the white terminal lock plate during inspection. If damage is present, a dark halo will be present around pin 11 of the VCM connector. Refer to the pictures below for examples.

**DAMAGE IS NOT PRESENT**

VCM connector, pin 11

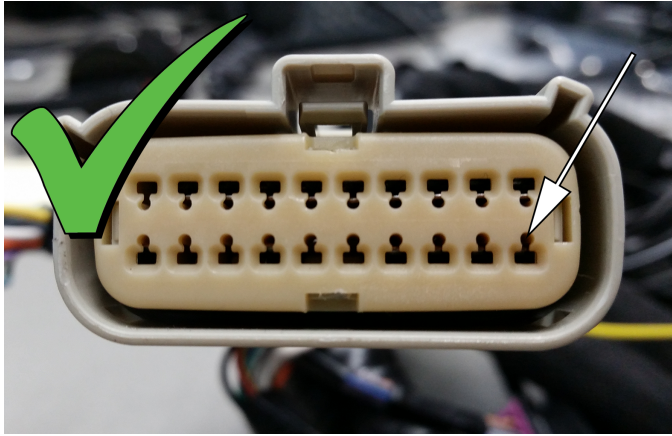

**DAMAGE IS PRESENT**

VCM connector, pin 11



Damage = Any sign of heat damage in or around pin 11 of the center VCM connector (e.g. the dark halo shown in the right image above).

**STOP!**

- If damage **IS** present, take pictures of the damage and proceed to I-19-02-B.  
US/CAN: Submit an Ask Polaris Service & Warranty Question> All Vehicle Diagnostic case.  
INT'L: Contact your Country Service Department.
- If damage is **NOT** present, proceed to step 11 to complete I-19-02-A or I-19-02-C.



## ASSEMBLY

11. Install the seat by sliding the seat forward to engage the retaining arms on the frame into the seat.

12. Loosely install both side seat fasteners ①.

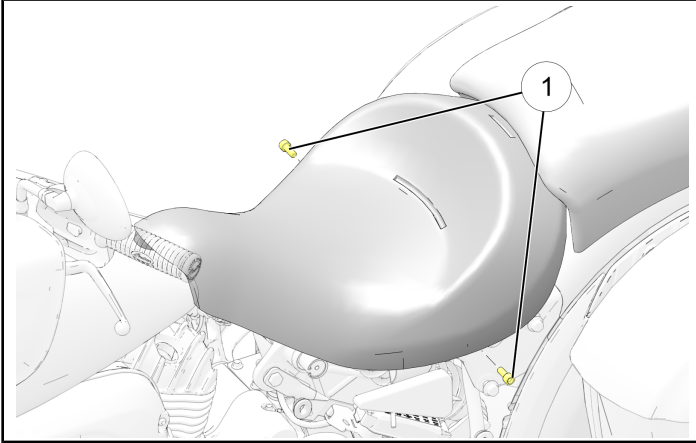

13. Loosely install the rear seat fastener ②.

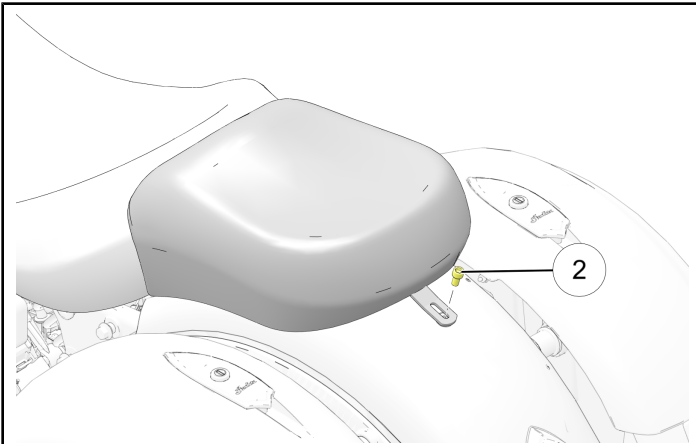

14. Torque all three seat fasteners to specification.

### TORQUE

Seat Fastener:  
**88 in-lbs (10 N·m)**

15. Install the side panels by aligning the side panel pins with the in-frame grommets and push inward to engage.

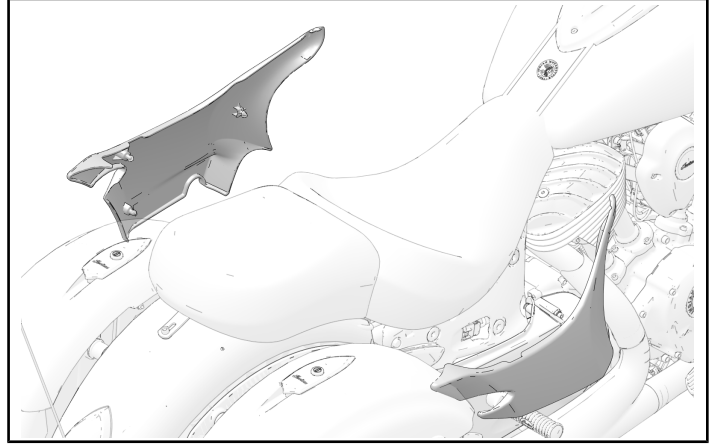

16. Install Accessory Trunk, if applicable.

### ⚠ CAUTION

Use care when installing the trunk assembly so that no electrical wires / connectors get pinched.

- Lift the flap at the rear of the passenger seat pad to access the vehicle side of the trunk harness connector and lay harness on fender.



- Reconnect the trunk harness connector ④.

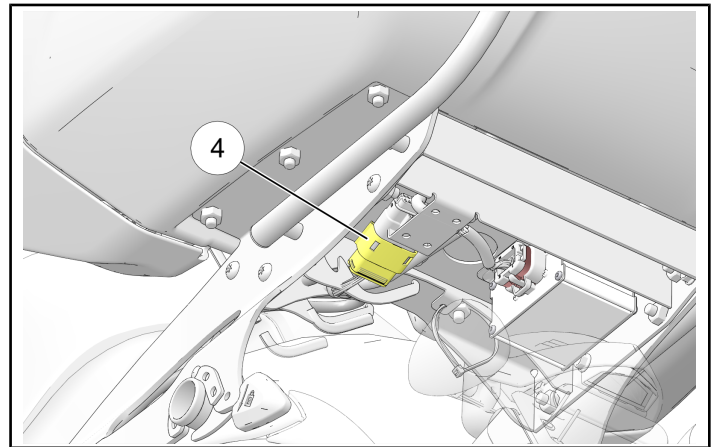

- Slide the trunk forward ① onto the mounting bracket and lower ② the rear of the trunk until fully seated.

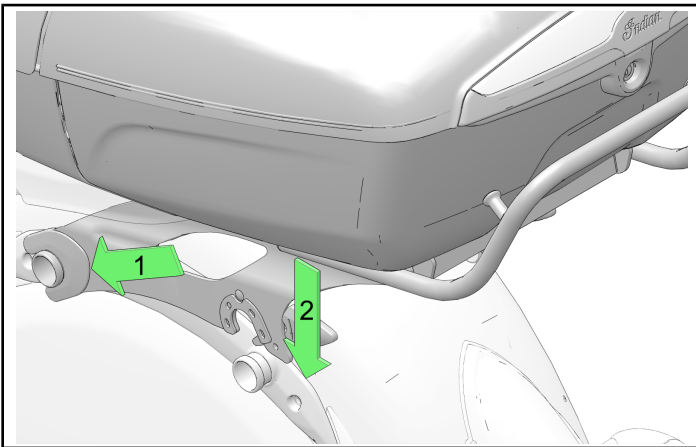

- If applicable, install the mounting fasteners ⑤ into left and right locking levers.

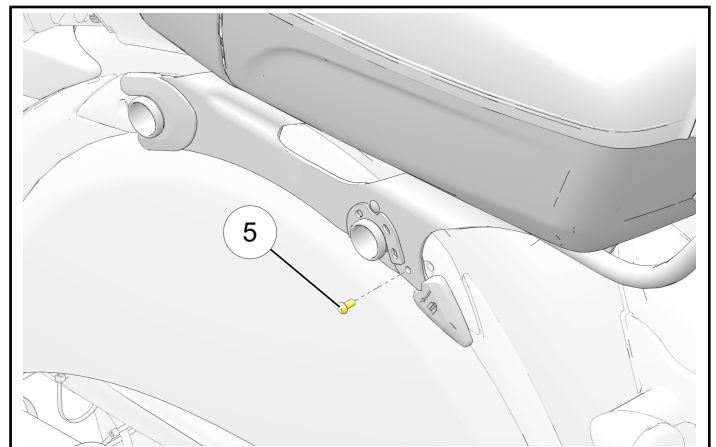

- Push the trunk locking levers ③ down until fully seated and the trunk is held securely in place.

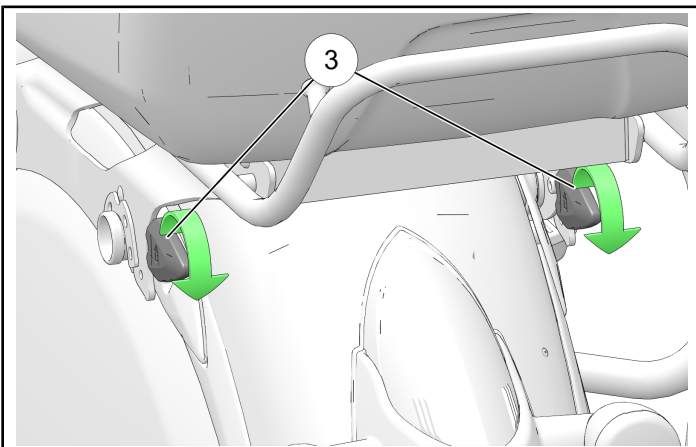

- Install saddlebags, if equipped.

17. If a VCM reflash is not needed, file a claim for I-19-02-C

**I-19-02-A ONLY  
VCM REFLASH**

**IMPORTANT**

This procedure requires the use of Digital Wrench® II. Connect a battery tender to the vehicle during the programming.

1. Park motorcycle on a flat surface, fully extend kickstand, and make sure vehicle is stable.
2. Turn off the motorcycle.
3. Verify that Digital Wrench II version 1.0.24 or later has been installed on your PC or laptop.

Also confirm that your multilink has been set up to Direct to USB.

For installation instructions, Click [HERE](#) to view the Digital Wrench II user manual or visit “Other Publications” on the left navigation menu of the DEX STOP site.

4. Connect MultiLink XP cables to PC and motorcycle. Then power on the motorcycle. Do **NOT** start.

**CAUTION**

Make sure the vehicle has sufficient battery voltage and is connected to a battery tender before the reflash. Failure to do so may result in a reflash crash and damage the VCM.

5. Open the Digital Wrench II application.
6. Select **Auto Identify**.

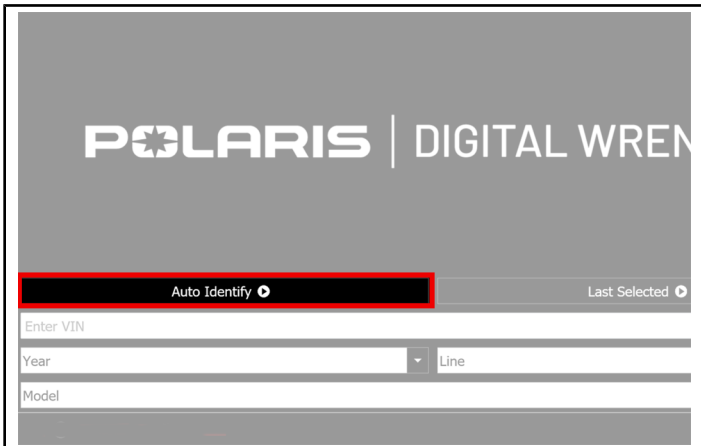

**7. Select Vehicle Update.**



**8. Put the motorcycle in 1st gear. Click continue button to finish.**

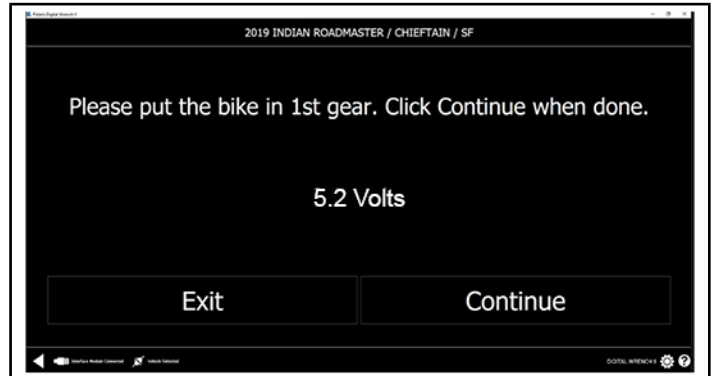

**NOTICE**

If I-20-03 has not been completed, the value could be different. Please refer to I-20-03.

**9. Select VEHICLE1. Then select Update ECU.**

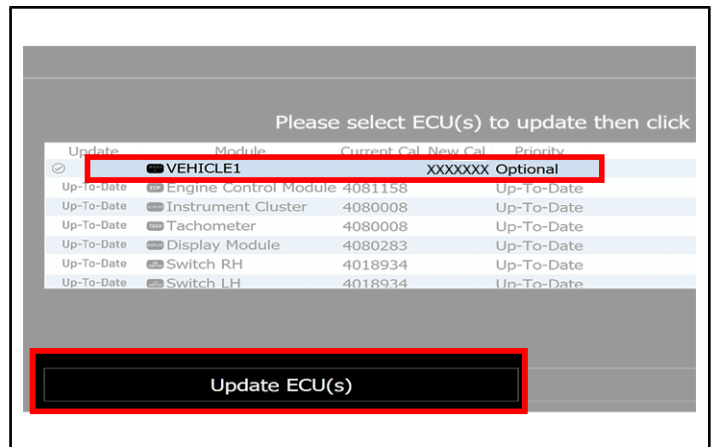

**NOTICE**

Digital Wrench II will automatically identify current software and determine if an update is required.

10. Select **Continue**.

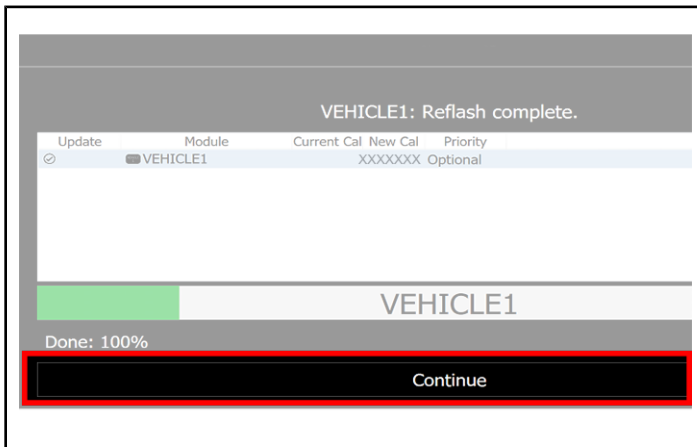

11. Once the update is complete, select the continue button then clear any trouble codes and power cycle the motorcycle.

12. Check / clear any stored fault codes, disconnect Digital Wrench and test ride the motorcycle.

**NOTICE**

Following the VCM reflash, some customers may notice a slight delay in illumination of their fog lights (if equipped) during vehicle use. This is normal and is intended to reduce current flow through the VCM

13. File a claim for I-19-02-A

IMPORTANT

**US/CAN Dealers:** Submit an Ask Polaris Service & Warranty Question > Vehicle Diagnostic Question case.

**INT'L Dealers:** Contact your Country Service Department.

**Submit photos of the dark halo present around VCM pin 11 on the white terminal lock plate and wait for further instructions from Indian Motorcycle Technical Service.**

**Do not allow the machine to be operated until you have repaired the machine as directed by Technical Service.**

**If damage is present at Pin 11, do not file a warranty claim until directed by Indian Motorcycle Technical Service.**